

AIR CONDITIONING SYSTEMS

CITY MULTI

DATA BOOK

MODEL

PWFY-P100VM-E-BU

PWFY-EP100VM-E1-AU

PWFY-EP100VM-E2-AU

PWFY-P-VM-E-BU, PWFY-EP-VM-E1-AU, PWFY-EP-VM-E2-AU

1. GENERAL EQUIPMENT DESCRIPTIONS	2
1-1. Unit configuration table	2
1-2. Operable temperature range	2
1-3. Connectable outdoor unit/heat source unit capacity range.....	2
2. SPECIFICATIONS	3
3. EXTERNAL DIMENSIONS	7
4. CENTER OF GRAVITY	10
5. ELECTRICAL WIRING DIAGRAMS	11
6. SOUND LEVELS	15
7. VIBRATION LEVELS	16
8. OPERATION TEMPERATURE RANGE	17
9. CAPACITY TABLES	20
9-1. Correction by temperature	20
9-2. Correction by total indoor.....	32
9-3. Correction by water volume	33
9-4. Water pressure drop	34
9-5. Water pressure drop of Strainer only	34
10.ACCESSORIES	35
11.OPTIONAL PARTS	36
11-1.Solenoid valve kit.....	36
11-2.Remote controller	37
12.ELECTRICAL WORK	38
12-1.General cautions	38
12-2.Power supply for PWFY unit.....	38
12-3.Power cable specifications	39
12-4.Connecting remote controller, indoor and outdoor transmission cables.....	40
12-5.Connecting electrical connections	41
13.CONTROL	43
13-1.Transmission cable specifications	43
13-2.Indoor unit address setting	44
13-3.External input/output function	45
14.PIPING DESIGN	47
14-1.Solenoid valve kit piping design	47
14-2.WCB piping design	48
14-3.Refrigerant charging calculation (PWFY-AU with R2 system).....	49
15.INSTALLATION	51
15-1.How to calculate the necessary heating capacity	51
15-2.Selecting an installation site	52
15-3.Securing installation and service space	52
15-4.Installing the unit.....	53
15-5.Refrigerant pipe and drain pipe specifications.....	54
15-6.Connecting refrigerant pipes and drain pipes	55
15-7.Water pipe installation	57

1-1. Unit configuration table

Model	PWFY-P100VM-E-BU		PWFY-EP100VM-E1-AU PWFY-EP100VM-E2-AU	
Outdoor unit	R2-Series	PURY-P Y(S)NW	Y-Series	PUHY-P Y(S)NW PUCY-P Y(S)KD PUHY-P Y(S)KD
			Y-Series (High efficiency)	PUHY-EP Y(S)NW PUCY-EP Y(S)KD PUHY-EP Y(S)KD
	R2-Series (High efficiency)	PURY-EP Y(S)NW	R2-Series	PURY-P Y(S)NW
			R2-Series (High efficiency)	PURY-EP Y(S)NW
Connection	BC controller	BC controller: CMB-M104,106,108,1012,1016V-J1 (-TR) Main BC controller: CMB-M108,1012,1016V-JA1 (-TR)/CMB-P1016V-KA1 (-TR) Sub BC controller: CMB-M104,108V-KB1 (-TR)		
	WCB	CMB-PW202V-J		

1-2. Operable temperature range

<PWFY-P100VM-E-BU>

		PWFY with standard indoor units
		Heating
Inlet water temperature	R2-Series R2-Series (High efficiency)	10 to 70°C
Outdoor temperature	R2-Series R2-Series (High efficiency)	-20 to 32°CWB

<PWFY-EP100VM-E1-AU, PWFY-EP100VM-E2-AU>

		PWFY with standard indoor units	
		Cooling	Heating
Inlet water temperature	R2-Series R2-Series (High efficiency)	10 to 35°C	10 to 40°C
	Y-Series Y-Series (High efficiency)	10 to 35°C	10 to 40°C
Outdoor temperature	R2-Series R2-Series (High efficiency)	-5 to 46°CDB	-20 to 32°CWB
	Y-Series Y-Series (High efficiency)	-5 to 46°CDB	-20 to 15.5°CWB

1-3. Connectable outdoor unit/heat source unit capacity range

<PWFY-P100VM-E-BU>

	PWFY with standard indoor units
R2-Series R2-Series (High efficiency)	50 to 150%*1

*1 In case of WCB connection, the capacity range will be "50 to 130%".

<PWFY-EP100VM-E1-AU, PWFY-EP100VM-E2-AU>

	PWFY with standard indoor units
R2-Series R2-Series (High efficiency)	50 to 150%*1
Y-Series Y-Series (High efficiency)	50 to 130%

*1 In case of WCB connection, the capacity range will be "50 to 130%".

<WCB>

	Connectable unit
CMB-PW202V-J	PURY-(E)P200-350YLM PURY-(E)P200-300YNW PQRY-P200-300YLM

2. SPECIFICATIONS

AIR TO WATER

Model			PWFY-P100VM-E-BU	
Power source			1-phase 220-230-240V 50/60Hz	
Heating capacity (Nominal)	*1	kW	12.5	
	*1	kcal / h	10,800	
	*1	BTU / h	42,700	
		Power input	kW	2.48
		Current input	A	11.63 - 11.12 - 10.66
Temp. range of heating	for outdoor unit		W.B	
	for heat source unit		-20~32°C (-4~90°F) R2-Series	
	for PWFY		10~45°C (50~113°F) WR2-Series 10~70°C (50~158°F)	
Connectable outdoor unit /heat source unit	Total capacity		50~100% of outdoor unit/heat source unit capacity	
	Model / Quantity		R2-Series R2-Series (High efficiency) WR2-Series	
Sound pressure level (measured in anechoic room)		dB<A>	44	
Diameter of refrigerant pipe	Liquid	mm(in.)	ø9.52 (ø3/8") Brazed	
	Gas	mm(in.)	ø15.88 (ø5/8") Brazed	
Diameter of water pipe	Inlet	mm(in.)	R3/4	
	Outlet	mm(in.)	Rc3/4	
Field drain pipe size		mm(in.)	ø32 (1-1/4")	

External finish			NO
External dimension H x W x D		mm	800 (785 without legs) x 450 x 300
		in.	31-1/2" (30-15/16" without legs) x 17-3/4" x 11-13/16"
Net weight		kg(lbs)	59 (131)
Compressor	Type		Inverter rotary hermetic compressor
	Maker		MITSUBISHI ELECTRIC CORPORATION
	Starting method		Inverter
	Motor output	kW	1.0
	Lubricant		NEO22
Circulating water	Operation volume	m³/h	0.6~2.15
	Range		
Protection on Internal circuit (R134a)	High pressure protection		High pressure sensor, High pressure switch at 3.60 MPa (601 psi)
	Inverter circuit (COMP)		Over-heat protection, Over-current protection
	Compressor		Discharge thermo protection, Over-current protection
Refrigerant	Type x original charge		R134a x 1.1kg (0.50lbs)
	Control		LEV
Design pressure	R410a	MPa	4.15
	R134a	MPa	3.60
	Water	MPa	1.00
Drawing	External		WKB94L762
	Wiring		WKE94C229
Standard attachment	Document		Installation Manual, Instruction Book
	Accessory		Strainer, Heat insulation material, wire x 1 set
Optional parts			NONE
Remark			Details on foundation work, duct work, insulation work, electrical wiring, power source switch, and other items shall be referred to the Installation Manual.

Note:	*1 Nominal heating conditions (PWFY conditions are indicated in the parentheses.) <R2-Series> Outdoor temp. : 7°CDB/6°CWB (45°FDB / 43°FWB) Pipe length : 7.5 m (24-9/16 ft) Level difference : 0 m (0 ft) (Inlet water temp. 65°C Water flow rate 2.15 m³/h)	<WR2-Series> Circulating water temp. : 20°C (68°F) Pipe length : 7.5 m (24-9/16 ft) Level difference : 0 m (0 ft) (Inlet water temp. for PWFY side 65°C Water flow rate 2.15 m³/h)	Unit converter BTU/h = kW x 3,412 cfm = m³/min x 35.31 lbs = kg / 0.4536
	* Due to continuing improvement, the above specifications may be subject to change without notice. * The unit is not designed for outside installations. * Please do not use the steel material for the water piping material. * Please always make water circulate or add the brine to the circulation water when the ambient temperature becomes 0°C or less. * Please always make water circulate or pull out the circulation water completely when not using it. * Please do not use ground water and well water.	* Install the outdoor unit (R2-Series) in an environment where the wet bulb temp. will not exceed 32°C. * The water circuit must use the closed circuit. * Please do not use it as a drinking water.	* The specification data is subject to rounding variation.

2. SPECIFICATIONS

AIR TO WATER

PW-FY-P-VM-E-BU, EP-VM-E1-AU, EP-VM-E2-AU

Model			PW-FY-EP100VM-E1-AU	
Power source			1-phase 220-230-240V 50/60Hz	
Heating capacity (Nominal)	*1	kW	12.5	
	*1	kcal / h	10,800	
	*1	BTU / h	42,700	
		Power input	kW	0.015
		Current input	A	0.068 - 0.065 - 0.063
Temp. range of heating	Outdoor temp. for outdoor unit	W.B	-20~32°C (-4~90°F) R2-Series	
		W.B	-20~15.5°C (-4~60°F) Y-Series	
		W.B	-25~15.5°C (-13~60°F) HP (ZUBADAN) -Series	
	Circulating Water temp. for heat source unit	-	10~45°C (50~113°F) WR2-Series	
Inlet Water temp. for PWFY	-	10~45°C (50~113°F) WY-Series		
			10~40°C (50~104°F) R2/Y/HP (ZUBADAN) /WR2/WY-Series	
Cooling capacity (Nominal)	*2	kW	11.2	
	*2	kcal / h	9,600	
	*2	BTU / h	38,200	
		Power input	kW	0.015
		Current input	A	0.068 - 0.065 - 0.063
Temp. range of cooling	Outdoor temp. for outdoor unit	D.B	-5~46°C (23~115°F) R2-Series	
		D.B	-5~46°C (23~115°F) Y-Series	
		D.B	-5~43°C (23~110°F) HP (ZUBADAN)-Series	
	Circulating Water temp. for heat source unit	-	10~45°C (50~113°F) WR2-Series	
Inlet Water temp. for PWFY	-	10~45°C (50~113°F) WY-Series		
			10~35°C (50~95°F)	
Connectable outdoor unit /heat source unit	Total capacity		50~100% of outdoor / heat source unit capacity	
	Model / Quantity		Y-Series Y-Series (High efficiency) R2-Series R2-Series (High efficiency) ZUBADAN-Series WY-Series WR2-Series	
Sound pressure level (measured in anechoic room)			dB<A> 29	
Diameter of refrigerant pipe	Liquid	mm(in.)	ø9.52 (ø3/8") Brazed	
	Gas	mm(in.)	ø15.88 (ø5/8") Brazed	
Diameter of water pipe	Inlet	mm(in.)	R1(R3/4 without expansion joint)	
	Outlet	mm(in.)	Rc1 (Rc3/4 without expansion joint)	
Field drain pipe size			mm(in.) ø32 (1-1/4")	
External finish			NO	
External dimension H × W × D		mm	800 (785 without legs) × 450 × 300	
		in.	31-1/2" (30-15/16" without legs) × 17-3/4" × 11-13/16"	
Net weight			kg(lbs) 33 (73)	
Circulating water	Operation Volume Range	m³/h	1.8~4.30	
Design pressure	R410a	MPa	4.15	
	Water	MPa	1.00	
Drawing	External		WKJ94T340	
	Wiring		WKE94C951	
Standard attachment	Document		Installation Manual, Instruction Book	
	Accessory		Strainer, Heat insulation material, Expansion joint, Flow switch x 1set. Buffer material.	
Optional parts			Solenoid valve kit: PAC-SV01PW-E	
Remark			Details on foundation work, duct work, insulation work, electrical wiring, power source switch, and other items shall be referred to the Installation Manual.	
Note: *1 Nominal heating conditions (PWFY conditions are indicated in the parentheses.)			Unit converter BTU/h = kW × 3.412 cfm = m³/min × 35.31 lbs = kg / 0.4536	
<Y/HP (ZUBADAN)/R2-Series> Outdoor temp. : 7°CDB/6°CWB (45°FDB/43°FWB) Pipe length : 7.5 m (24-9/16 ft.) Level difference : 0 m (0 ft.) (Inlet water temp. 30°C, Water flow rate 4.30 m³/h)				
*2 Nominal cooling conditions (PWFY conditions are indicated in the parentheses.) <Y/HP (ZUBADAN)/R2-Series> Outdoor temp. : 35°CDB (95°FDB) Pipe length : 7.5 m (24-9/16 ft.) Level difference : 0 m (0 ft.) (Inlet water temp. 23°C, Water flow rate 3.86 m³/h)			* The specification data is subject to rounding variation.	
<WY/WR2-Series> Circulating water temp. : 20°C (68°F) Pipe length : 7.5 m (24-9/16 ft.) Level difference : 0 m (0 ft.) (Inlet water temp. for PWFY side 30°C, Water flow rate 4.30 m³/h)				
* Due to continuing improvement, the above specifications may be subject to change without notice.			* Install the outdoor unit (R2-Series) in an environment where the wet bulb temp. will not exceed 32°C	
* The unit is not designed for outside installations.			* The water circuit must use the closed circuit.	
* Please don't use the steel material for the water piping material.			* Please do not use it as a drinking water.	
* Please always make water circulate or add the brine to the circulation water when the ambient temperature becomes 0°C or less.				
* Please always make water circulate or pull out the circulation water completely when not using it.				
* Please do not use ground water and well water.				

2. SPECIFICATIONS

AIR TO WATER

Model		PWFY-EP100VM-E2-AU	
Power source		1-phase 220-230-240V 50/60Hz	
Heating capacity (Nominal)	*1 kW	12.5	
	*1 kcal / h	10,800	
	*1 BTU / h	42,700	
	Power input	kW 0.025 - 0.026 - 0.027	
	Current input	A 0.138 - 0.139 - 0.140	
Temp. range of heating	Outdoor temp. for outdoor unit	W.B	-20~32°C (-4~90°F) R2-Series
		W.B	-20~15.5°C (-4~60°F) Y-Series
		W.B	-25~15.5°C (-13~60°F) HP (ZUBADAN) -Series
	Circulating Water temp. for heat source unit	-	10~45°C (50~113°F) WR2-Series
		-	10~45°C (50~113°F) WY-Series
Inlet Water temp. for PWFY	-	10~40°C (50~104°F) R2/Y/HP (ZUBADAN) /WR2/WY-Series	
Cooling capacity (Nominal)	*2 kW	11.2	
	*2 kcal / h	9,600	
	*2 BTU / h	38,200	
	Power input	kW 0.025 - 0.026 - 0.027	
	Current input	A 0.138 - 0.139 - 0.140	
Temp. range of cooling	Outdoor temp. for outdoor unit	D.B	-5~46°C (23~115°F) R2-Series
		D.B	-5~46°C (23~115°F) Y-Series
		D.B	-5~43°C (23~110°F) HP (ZUBADAN)-Series
		D.B	-5~43°C (23~110°F) HP (ZUBADAN)-Series
	Circulating Water temp. for heat source unit	-	10~45°C (50~113°F) WR2-Series
-		10~45°C (50~113°F) WY-Series	
Inlet Water temp. for PWFY	-	10~35°C (50~95°F)	
Connectable outdoor unit /heat source unit	Total capacity	50~100% of outdoor / heat source unit capacity	
	Model / Quantity	Y-Series Y-Series (High efficiency) R2-Series R2-Series (High efficiency) ZUBADAN-Series WY-Series WR2-Series	
Sound pressure level (measured in anechoic room)	dB<A>	29	
Diameter of refrigerant pipe	Liquid	mm(in.)	ø9.52 (ø3/8") Brazed
	Gas	mm(in.)	ø15.88 (ø5/8") Brazed
Diameter of water pipe	Inlet	mm(in.)	R1 (R3/4 without expansion joint)
	Outlet	mm(in.)	Rc1 (Rc3/4 without expansion joint)
Field drain pipe size	mm(in.)	ø32 (1-1/4")	

External finish		NO	
External dimension H × W × D	mm	800 (785 without legs) × 450 × 300	
	in.	31-1/2" (30-15/16" without legs) × 17-3/4" × 11-13/16"	
Net weight	kg(lbs)	36 (80)	
Circulating water	Operation Volume	m³/h	1.8~4.30
	Range		
Design pressure	R410a	MPa	4.15
	Water	MPa	1.00
Drawing	External	WKJ94T340	
	Wiring	WKE94C953	
Standard attachment	Document	Installation Manual, Instruction Book	
	Accessory	Strainer, Heat insulation material, Expansion joint, Flow switch × 1 set, Buffer material.	
Optional parts	NONE		
Remark	Details on foundation work, duct work, insulation work, electrical wiring, power source switch, and other items shall be referred to the Installation Manual.		

Note:	*1 Nominal heating conditions (PWFY conditions are indicated in the parentheses.) <Y/HP (ZUBADAN)/R2-Series> Outdoor temp. : 7°CDB/6°CWB (45°FDB/43°FWB) Pipe length : 7.5 m (24-9/16 ft.) Level difference : 0 m (0 ft.) (Inlet water temp. 30°C, Water flow rate 4.30 m³/h)	<WY/WR2-Series> Circulating water temp. : 20°C (68°F) Pipe length : 7.5 m (24-9/16 ft.) Level difference : 0 m (0 ft.) (Inlet water temp. for PWFY side 30°C, Water flow rate 4.30m³/h)	Unit converter BTU/h = kW × 3,412 cfm = m³/min × 35.31 lbs = kg / 0.4536 * The specification data is subject to rounding variation.
	*2 Nominal cooling conditions (PWFY conditions are indicated in the parentheses.) <Y/HP (ZUBADAN)/R2-Series> Outdoor temp. : 35°CDB (95°FDB) Pipe length : 7.5 m (24-9/16 ft.) Level difference : 0 m (0 ft.) (Inlet water temp. 23°C, Water flow rate 3.86m³/h)	<WY/WR2-Series> Circulating water temp. : 30°C (86°F) Pipe length : 7.5 m (24-9/16 ft.) Level difference : 0 m (0 ft.) (Inlet water temp. for PWFY side 23°C, Water flow rate 3.86m³/h)	
	* Due to continuing improvement, the above specifications may be subject to change without notice.	* Install the outdoor unit (R2-Series) in an environment where the wet bulb temp. will not exceed 32°C	
	* The unit is not designed for outside installations.	* The water circuit must use the closed circuit.	
	* Please don't use the steel material for the water piping material.	* Please do not use it as a drinking water.	
	* Please always make water circulate or add the brine to the circulation water when the ambient temperature becomes 0°C or less.		
	* Please always make water circulate or pull out the circulation water completely when not using it.		
	* Please do not use ground water and well water.		

2. SPECIFICATIONS

AIR TO WATER

Model		CMB-PW202V-J					
Number of branch		2					
Power source		1N ~ 220/230/240V					
Power input	kW	50Hz		60Hz			
		Cooling : 0.019/0.020/0.021 Heating : 0.020/0.022/0.024		Cooling : 0.018/0.019/0.019 Heating : 0.019/0.020/0.021			
Current	A	Cooling : 0.09/0.09/0.09 Heating : 0.10/0.10/0.10		Cooling : 0.09/0.09/0.09 Heating : 0.09/0.09/0.09			
External finish		Galvanized steel plate (Lower part drain pan painting N1.5)					
Connectable outdoor unit/heat source unit		PURY-(E)P200/250/300/350YLM PURY-(E)P200/250/300YNW PQRY-P200/250/300YLM					
Connectable unit capacity	Total	50% ~ 130% of outdoor unit/heat source unit					
	Indoor / PWFY branch	up to 130% of outdoor unit/heat source unit					
	PWFY branch	up to 100% of outdoor unit/heat source unit					
External dimension H x W x D		284 x 648 x 432 (11-3/16" x 25-9/16" x 17-1/16")					
Refrigerant piping diameter	To outdoor unit /heat source unit	High press. pipe	mm(in.)	Connectable outdoor unit capacity			
				P200	P250/P300	P350	
		Low press. pipe		mm(in.)		mm(in.)	
		mm(in.)		mm(in.)		mm(in.)	
	To indoor/ PWFY unit	Liquid pipe	mm(in.)	Total down-stream Indoor unit capacity			
				~P140	P141~P200	P201~P300	P301~P400
		Gas pipe		mm(in.)		mm(in.)	
		mm(in.)		mm(in.)		mm(in.)	
Field drain pipe size		O.D. 32mm (1-1/4")					
Net weight		kg(lbs)					
Accessories		·Drain Connection pipe (with flexible hose and insulation) ·Refrigerant connection pipe					
<p>Note:</p> <ul style="list-style-type: none"> *1. For installation/foundation work, electrical connection work, insulation work, and power source switch etc., refer to the Installation Manual. *2. The equipment is for R410A refrigerant. *3. Install this product in a location where noise (refrigerant noise) emitted by the unit will not disturb the neighbors. (For use in quiet environments with low background noise, position the Water system Connection Box at least 5m away from any indoor units.) *4. Install the unit horizontally. *5. The indoor / PWFY unit branch is for cooling / heating. The indoor / PWFY unit cannot be simultaneously operated in different operation modes. *6. The PWFY unit branch is for the heating only. *7. Seal the unused branch using the optional cover cap (CMY-S202-J). 							

PWFY-P-VM-E-BU,EP-VM-E1-AU, EP-VM-E2-AU

PWFY-P100VM-E-BU

Unit: mm

- <Accessories>
- Y-type strainer (RC3/4) 1pc.
 - Heat insulation material 1pc.
 - Wire 1pc.

- Note 1. Ensure no water or debris can enter the unit through any gaps around wiring or piping.
2. Ensure adequate both service and piping space as shown in Fig A.
3. Please always make water circulate or add the brine to the circulation water when the ambient temperature becomes 0°C or below.
4. The unit is not designed for outside installations.
5. Please always make water circulate or remove all circulation water completely when not in operation.
6. The water circuit must be the closed circuit.
7. Please don't use the steel material for the water piping.
8. Connect the strainer as accessory for unit to water inlet pipe.

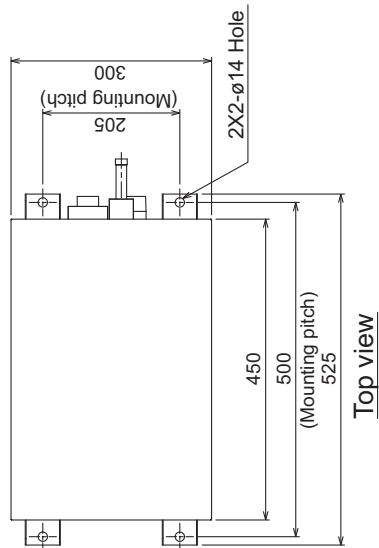

Top view

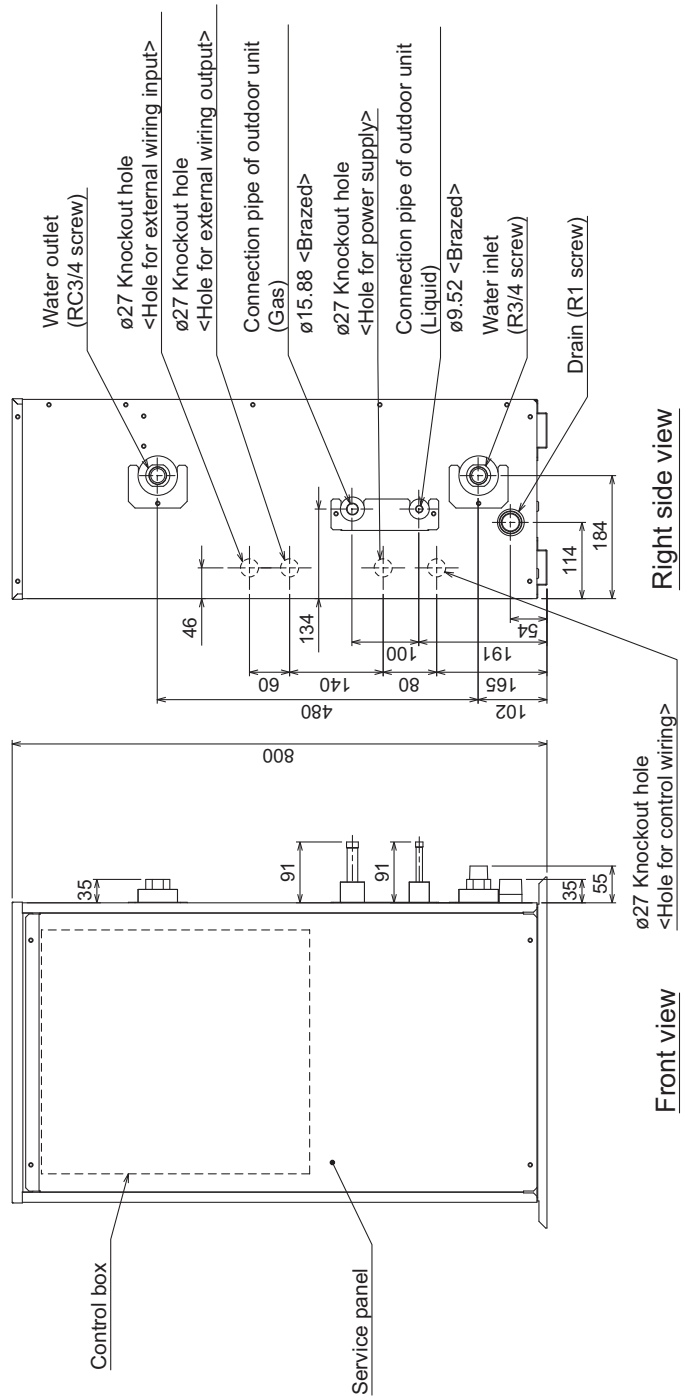

Right side view

Front view

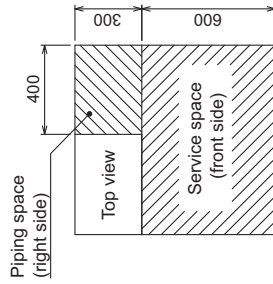

Fig. A

PWFY-EP100VM-E1-AU, PWFY-EP100VM-E2-AU

Unit: mm

- <Accessories>
- Y-type strainer(RC3/4)..... 1pc.
 - Heat insulation material..... 1pc.
 - Expansion joint..... 2pcs.
[From RC3/4 to RC1]
 - Flow switch..... 1set
 - Buffer material..... 1pc.

- Note 1. Ensure no water or debris can enter the unit through any gaps around wiring or piping.
2. Ensure adequate both service and piping space, as shown in Fig A.
3. Please always make water circulate or add the brine to the circulation water when the ambient temperature becomes 0°C or below.
4. The unit is not designed for outside installations.
5. Please always make water circulate or remove all circulation water completely when not in operation.
6. The water circuit must be the closed circuit.
7. Please don't use the steel material for the water piping.
8. Connect the strainer as accessory for unit to water inlet pipe.

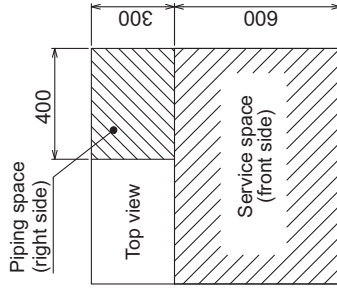
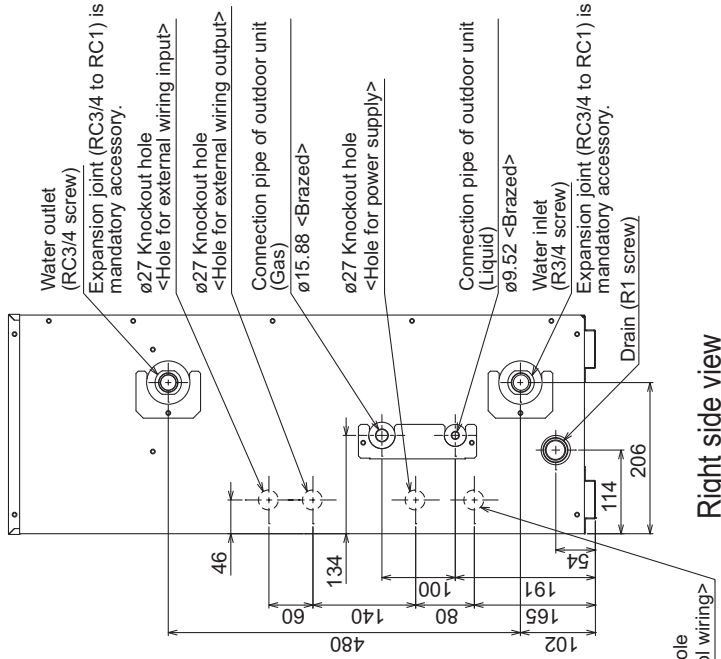
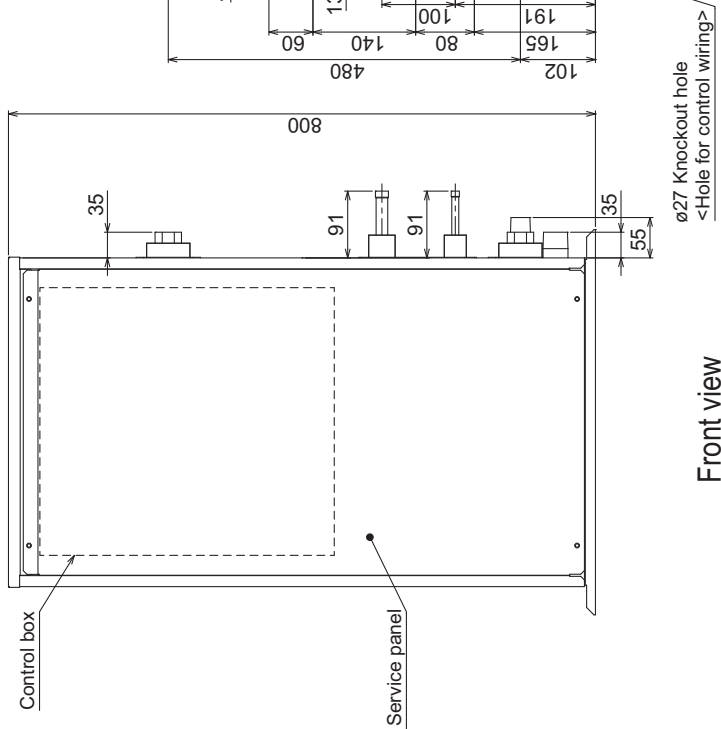
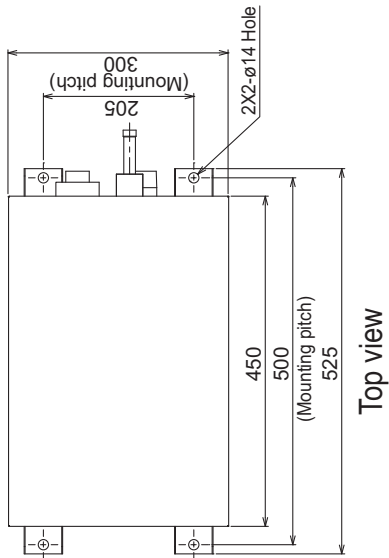

CMB-PW202V-J

Unit: mm

- <Accessories>
 Refrigerant<Low pressure> conn. pipe 2pcs.
 Refrigerant<High pressure> conn. pipe 1pc.
 Refrigerant<Gas> conn. pipe 6pcs.
 Refrigerant<Liquid> conn. pipe 2pcs.
 Drain hose(VP-25 connection) 1pc.
 Hose band 1pc.
 Tie band 1pc.

- Note1. Suspension bolt (ø10), washer (M10), and nut (M10) prepare in the field.
 2. Take notice of service space as follows.
 (Please give attention not to occupy service space by letting ducts and pipes through.)
 3. Install this product in a location where noise (refrigerant noise) emitted by the unit will not disturb the neighbors.
 (For use in quiet environments with low background noise, position the BC CONTROLLER at least 5m away from any indoor units.)
 4. Install the unit horizontally.
 5. The indoor unit/PWFY branch is for cooling/heating. The indoor unit/PWFY cannot be simultaneously operated in different operation modes.
 6. The PWFY unit branch is for the heating only.

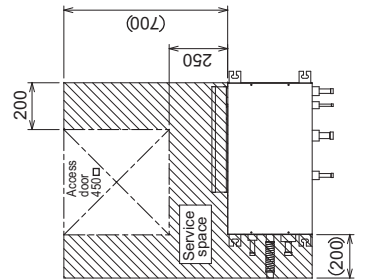
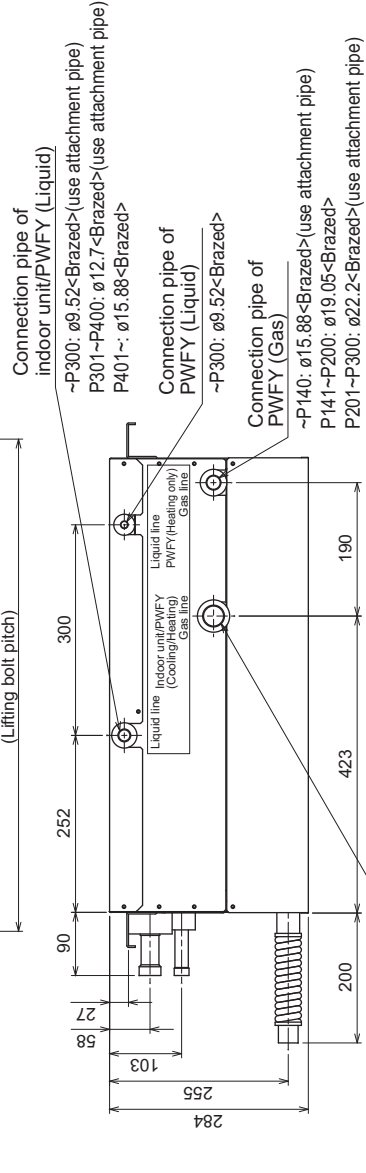
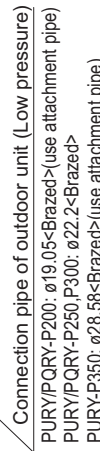
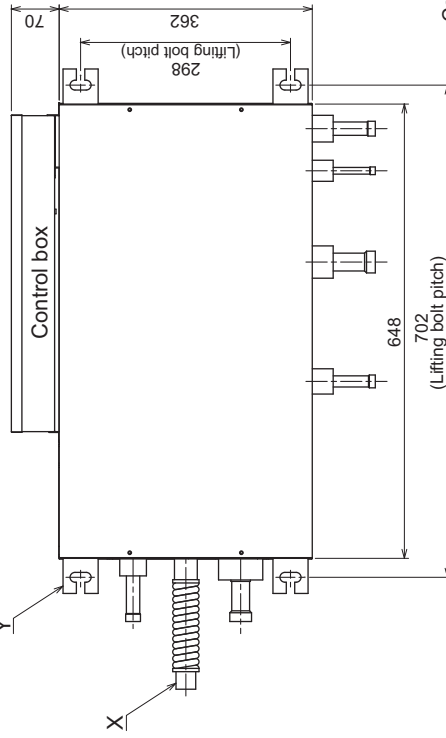
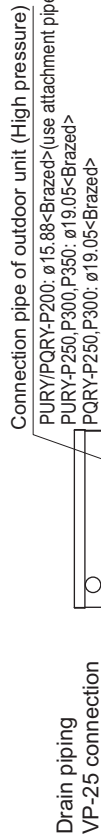
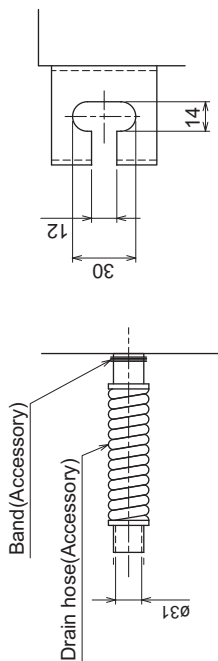

PWFY-P100VM-E-BU

PWFY-P-VM-E-BU, EP-VM-E1-AU, EP-VM-E2-AU

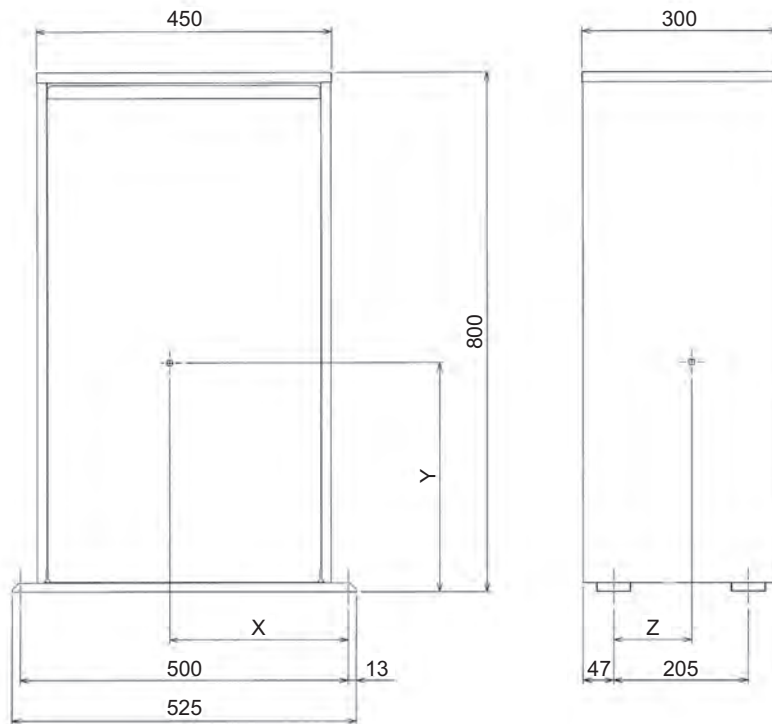

Unit: mm

Model	X	Y	Z
PWFY-P100VM-E-BU	272	355	119

PWFY-EP100VM-E1/E2-AU

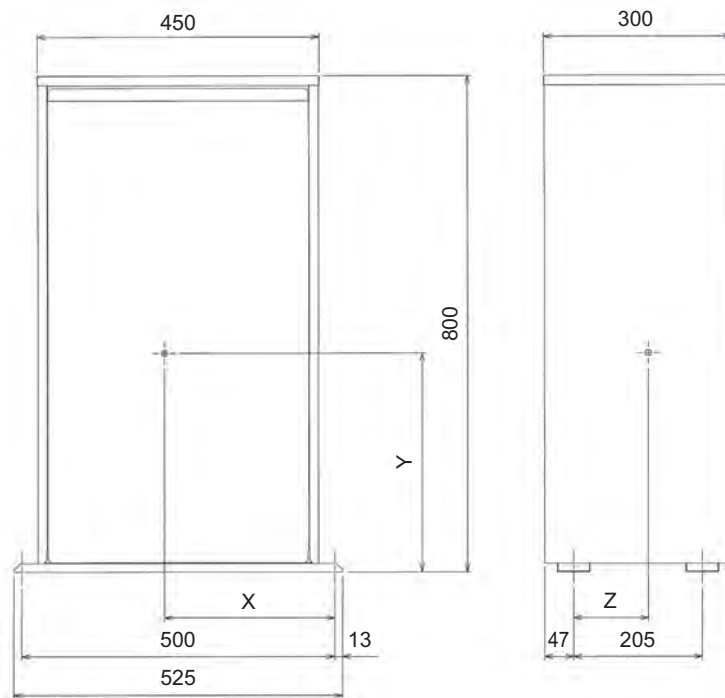

Unit: mm

Model	X	Y	Z
PWFY-EP100VM-E1-AU	295	345	106
PWFY-EP100VM-E2-AU	265	353	103

PWFY-P100VM-E-BU

- <HIGH VOLTAGE WARNING>**
 • Control box houses high-voltage parts.
 • Before inspecting the inside of the control box, turn off the power, keep the unit off for at least 10 minutes, and confirm that the voltage CN631 on Control Board has dropped to DC20V or less.
<CAUTION FOR INSTALLATION>
 • Prior to installation, read the Installation Manual carefully.
 • 1. Single-dotted lines indicate wiring not supplied with the unit.
 • 2. Dot-dash lines indicate the control box boundaries.
 • 3. Faston terminals have a locking function.
 Make sure the terminals are securely locked in place after insertion. Press the tab on the terminals to removed them.

- *4 TB141A(output)
- | | |
|--------|------------------|
| Symbol | Function |
| OUT1 | Operation ON/OFF |
| OUT2 | Operation ON/OFF |
| OUT3 | Compressor |
| OUT4 | Error signal |
- *5 TB142A(input)
- | | |
|--------|----------------|
| Symbol | Function |
| INT | Pump interlock |
- *6 TB142B(input)
- | | |
|--------|-------------------|
| Symbol | Function |
| IN3 | Connection demand |
| IN4 | Operation ON/OFF |
- *7 TB142C(input)
- | | |
|--------|-------------|
| Symbol | Function |
| COM+ | Common |
| IN6 | Heating ECC |
| IN7 | Anti-freeze |

<Symbol explanation>

Symbol	Explanation
63H1	Pressure switch (High pressure protection for the booster unit)
63HS	Pressure switch (High pressure protection for the booster unit)
63S	Pressure switch (Low pressure protection for the booster unit)
52CS	Magnetic relay(main circuit)
ACL	AC reactor
CT1,CT2	Current sensor(AC)
LEV1W	Linear expansion valve
LEV2W	Linear expansion valve
TB2	Terminal block
TB5	Terminal block
TH15	Thermistor outdoor discharge temp
TH13	Thermistor evaporator outlet temp
TH22	Thermistor liquid pipe temp
TH6	Thermistor water inlet temp
TH8	Thermistor water outlet temp
THHS	Thermistor IGBT temp

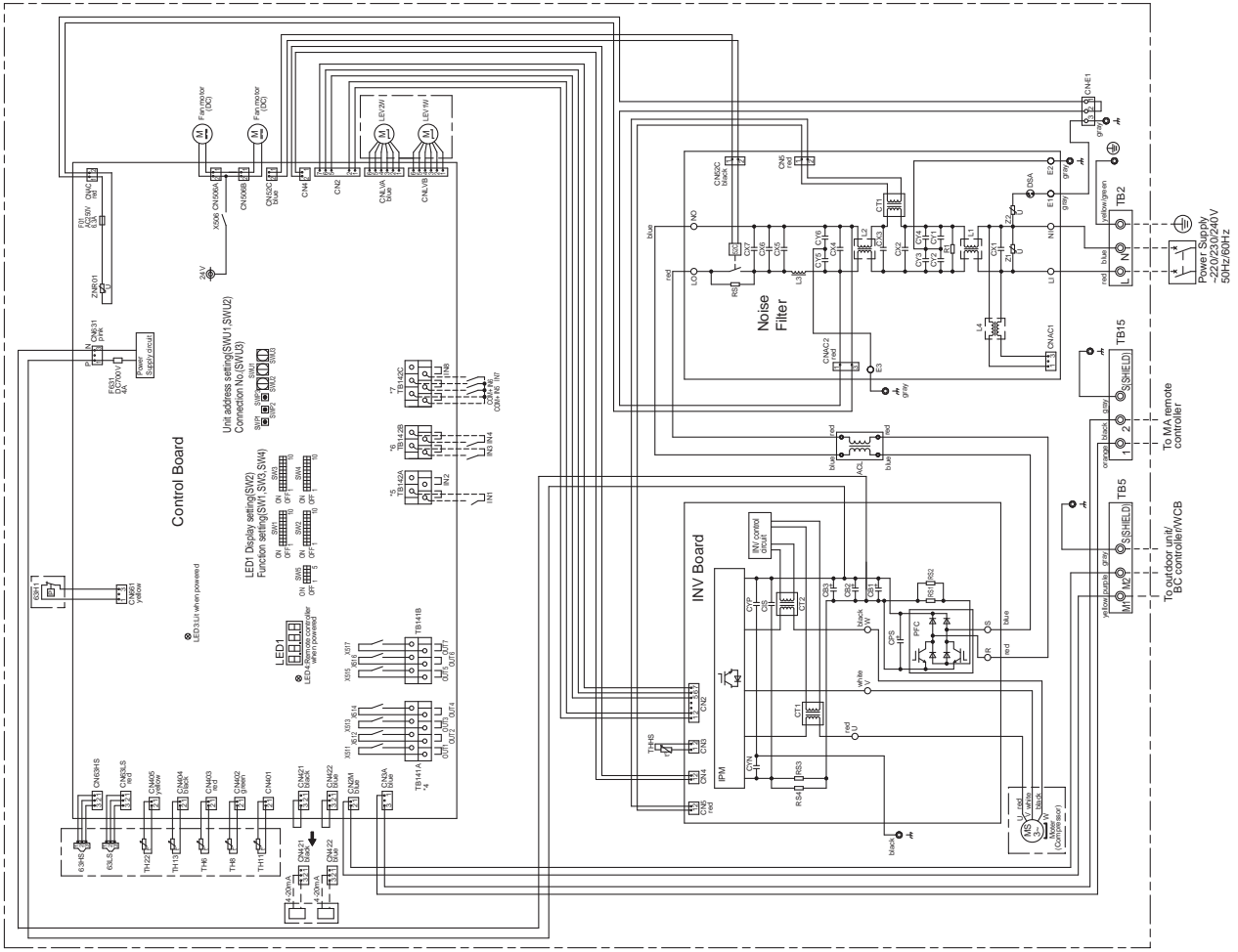

PWFY-EP100VM-E1-AU

<CAUTION FOR INSTALLATION>

- Prior to installation, read the Installation Manual carefully.
- *1. Single-dotted lines indicate wiring not supplied with the unit.
- *2. Dot-dash lines indicate the control box boundaries.
- *3. TB141A (output)

Symbol	Function
OUT1	Operation ON/OFF
OUT2	Defrost
OUT4	Error signal
OUT3	is no function.

*4. TB142A (input)

Symbol	Function
IN1	Flow switch

*5. TB142B (input)

Symbol	Function
IN3	Compressor demand
IN4	Operation ON/OFF

*6. TB142C (input)

Symbol	Function
COM+	Common
IN5	Heating
IN6	Heating ECO
IN7	Anti-freeze
IN8	Cooling

<Symbol explanation>

Symbol	Explanation	For opening/closing the bypass circuit
LEV1/Wa	Solenoid valve expansion valve BC controller/outdoor unit	
TB2	Terminal block	
TB5	Outdoor unit/BC controller	
TB15	MA remote controller	
TH22	liquid pipe temp	
TH23	gas pipe temp	
TH6	water inlet temp	
TH8	water outlet temp	

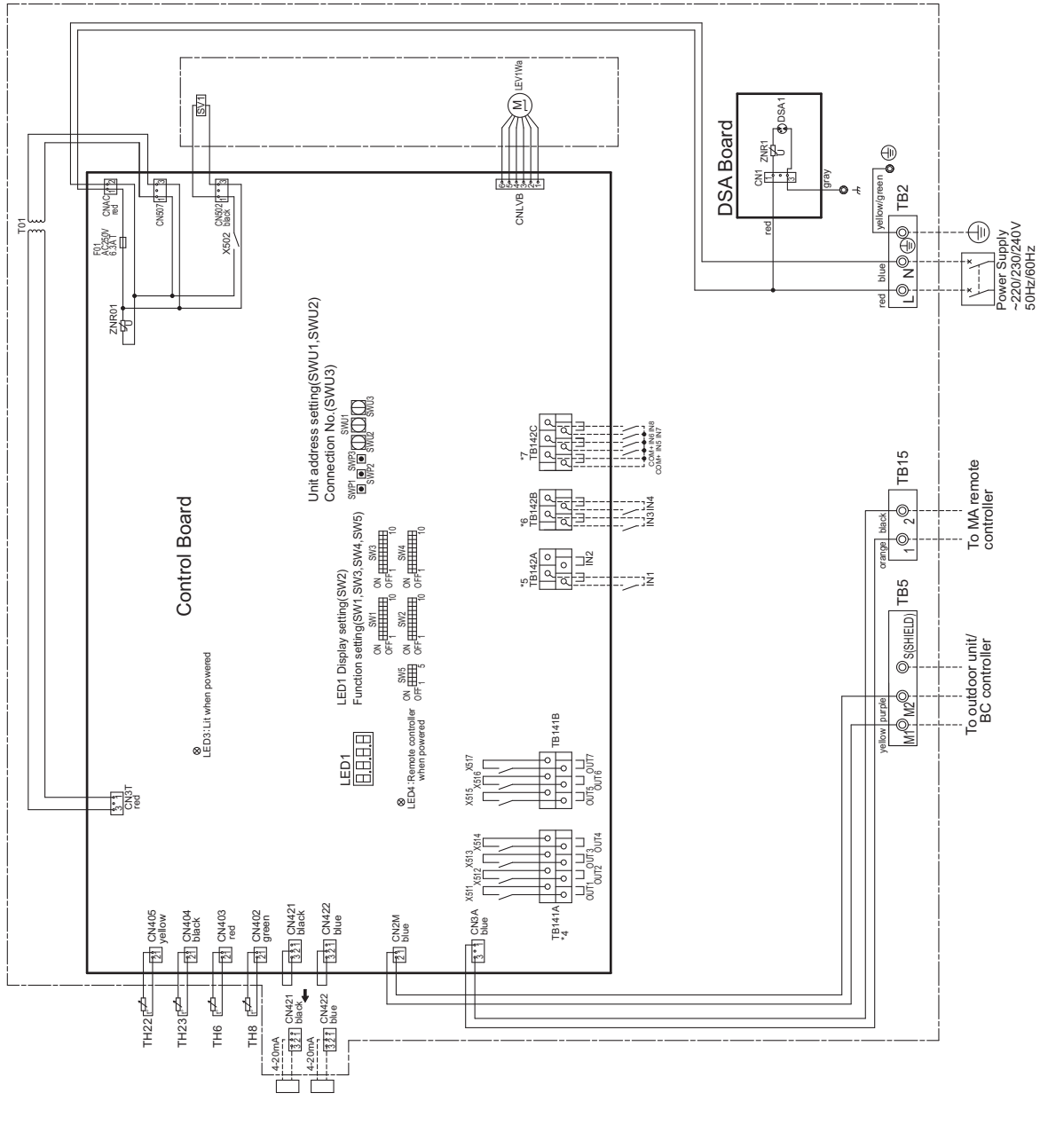

PWFY-EP100VM-E2-AU

<CAUTION FOR INSTALLATION>

·Prior to installation,read the Installation Manual carefully.

- *1.Single-dotted lines indicate wiring not supplied with the unit.
- *2.Dot-dash lines indicate the control box boundaries.
- *3.TB141A(output)

Symbol	Function
OUT1	Operation ON/OFF (Voltage contact)
OUT2	Defrost
OUT4	Error signal

OUT3 is no function.

*4. TB142A(input)

Symbol	Function
IN1	Flow switch

*5. TB142B(input)

Symbol	Function
IN3	Connection demand
IN4	Operation ON/OFF

*6. TB142C(input)

Symbol	Function
COM1P	Common
IN5	Heating
IN6	Heating ECO
IN7	Anti-freeze
IN8	Cooling

<Symbol explanation>

Symbol	Explanation
SV6	Solenoid valve
SV1	For opening/closing the bypass circuit
SV2	For opening/closing the liquid refrigerant circuit
SV3	For opening/closing the liquid refrigerant circuit
LEV1/Wa	Linear expansion valve
TB2	Terminal block
TB5	Terminal block
TB15	Terminal block
TH2.3	Thermistor
TH6	Water inlet temp.
TH8	water outlet temp.

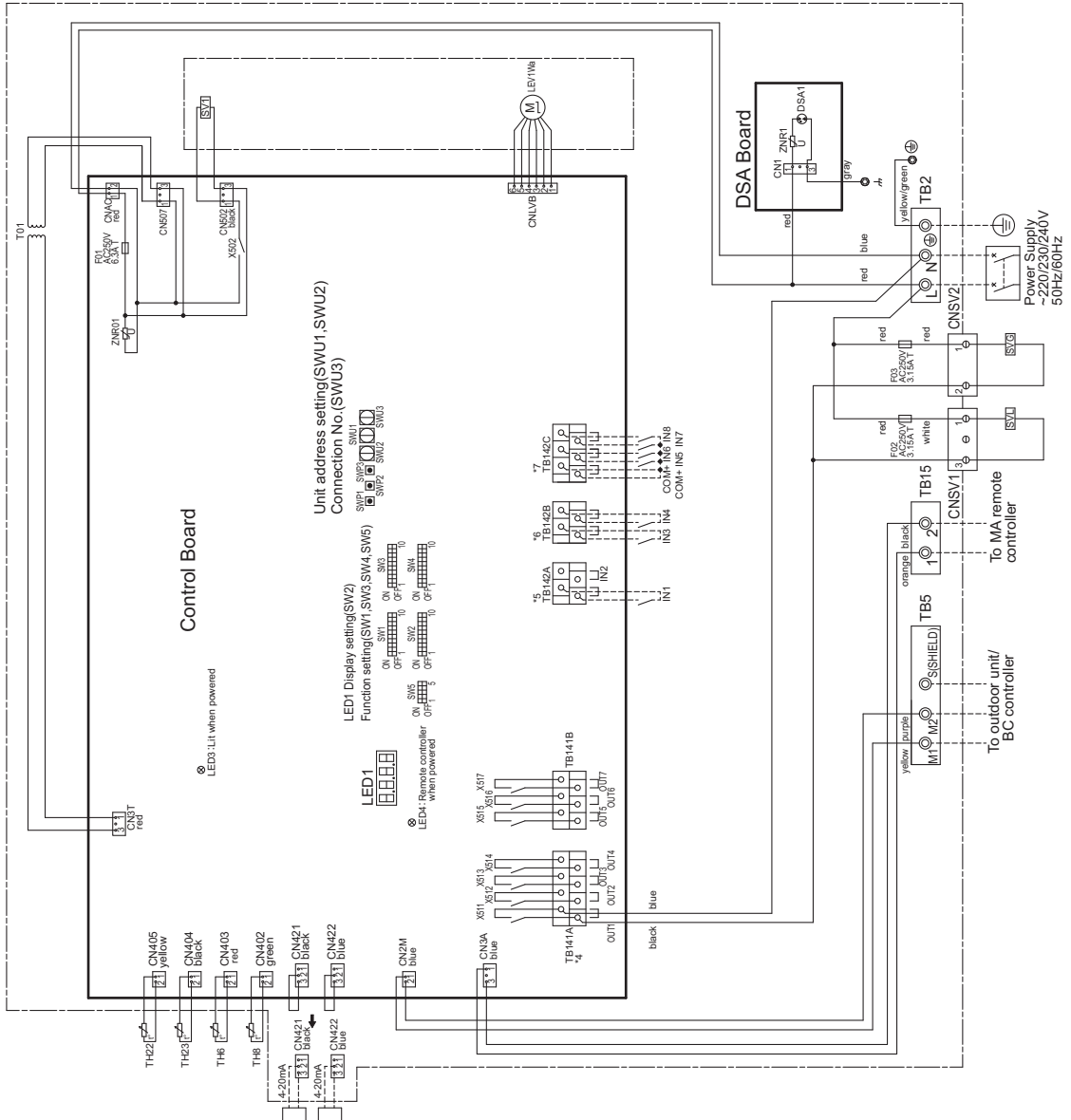

CMB-PW202V-J

(Symbol explanation)	Symbol	Name
	TR	Transformer
	TH11~16	Thermistor sensor
	LEV1,3	Expansion valve
	TB01	Terminal block (for power source)
	TB02	Terminal block (for Transmission)
	SVM1	Solenoid valve
	Z1S4a	4-way valve
	F01	Fuse AC250V 6.3A F

Note:1. TB02 is transmission terminal block.
Never connect power line to it.
2. The initial set values of switch on WCB Board are as follows.
SW1:0
SW2:0

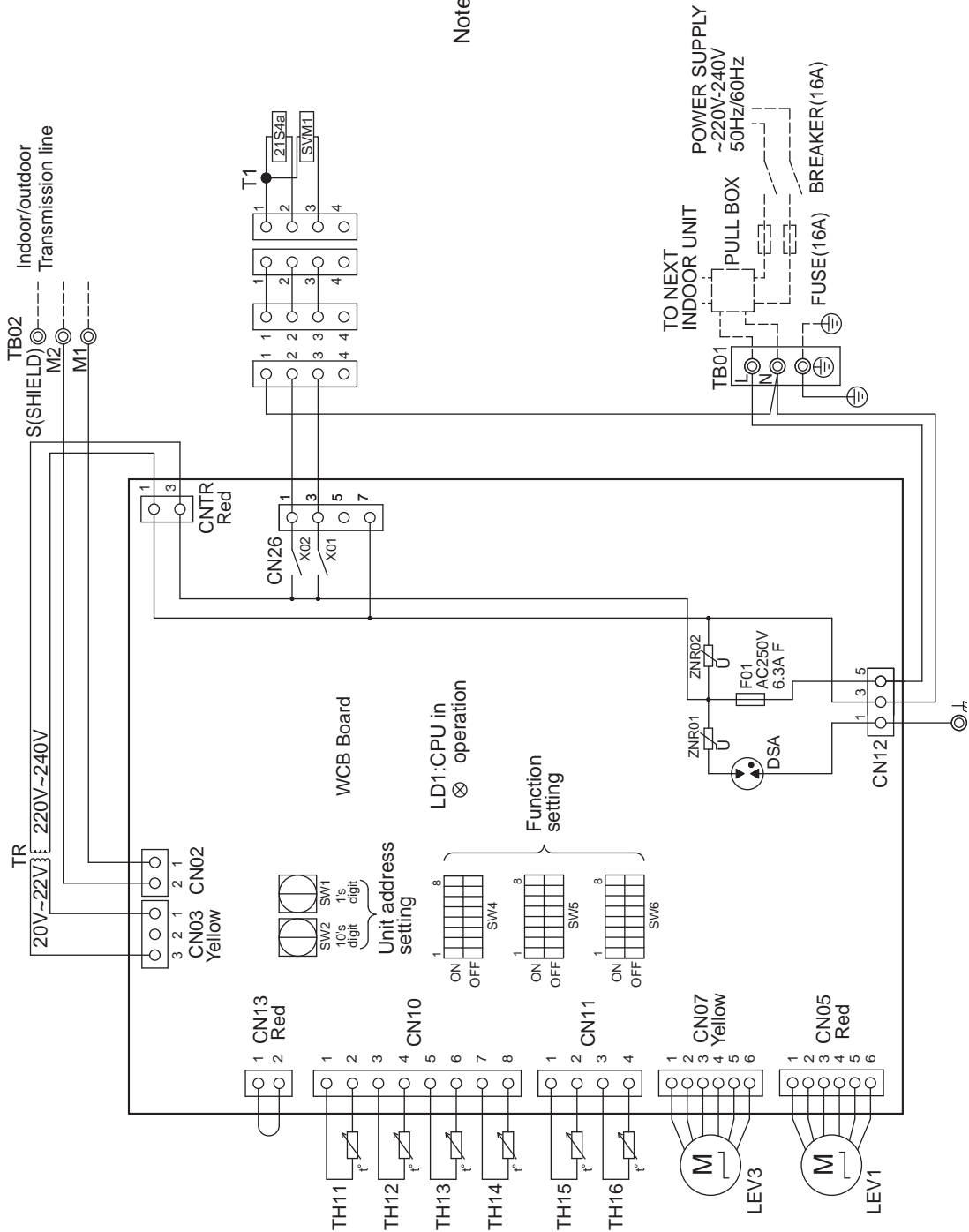

Measurement condition
PWFY-P100VM-E-BU

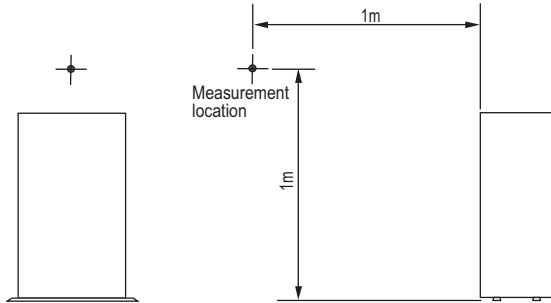

Sound level of PWFY-P100VM-E-BU

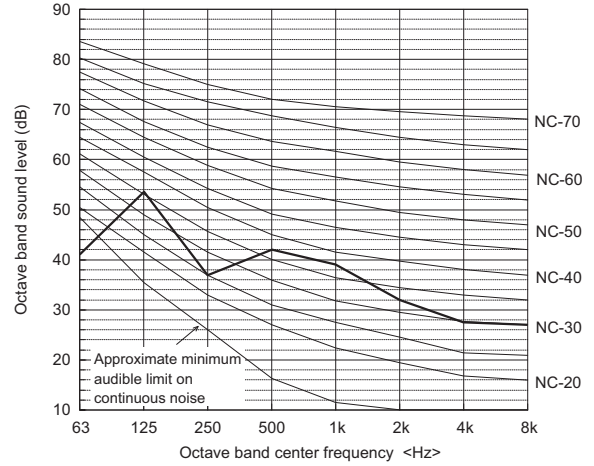

	63	125	250	500k	1k	2k	4k	8k	dB(A)
50/60Hz	41.0	53.5	37.0	42.0	39.0	32.0	27.5	27.0	44.0

When Low noise mode is set, the A/C system's capacity is limited. The system could return to normal operation from Low noise mode automatically in the case that the operation condition is severe.

Measurement condition
PWFY-EP100VM-E1-AU, PWFY-EP100VM-E2-AU

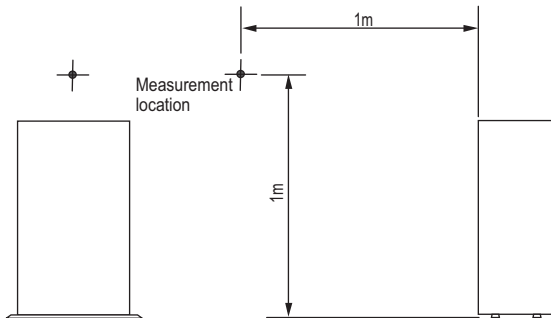

Sound level of PWFY-EP100VM-E1/E2-AU

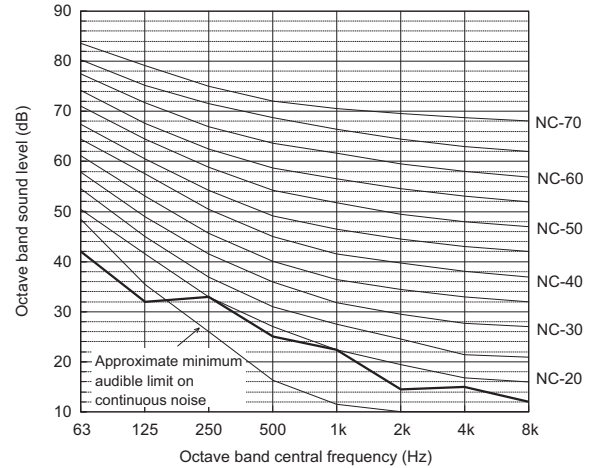

	63	125	250	500k	1k	2k	4k	8k	dB(A)
50/60Hz	42.0	32.0	33.0	25.0	22.5	14.5	15.0	12.0	29.0

When Low noise mode is set, the A/C system's capacity is limited. The system could return to normal operation from Low noise mode automatically in the case that the operation condition is severe.

PWFY-P100VM-E-BU

PWFY-P-VM-E-BU, EP-VM-E1-AU, EP-VM-E2-AU

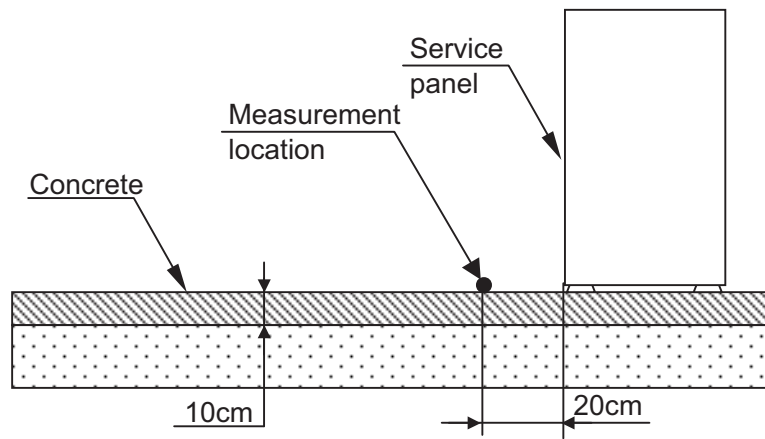

Model	Vibration Levels[dBA]
PWFY-P100VM-E-BU	34

PWFY-P100VM-E-BU

R2-Series, R2-Series (High efficiency)

Heating

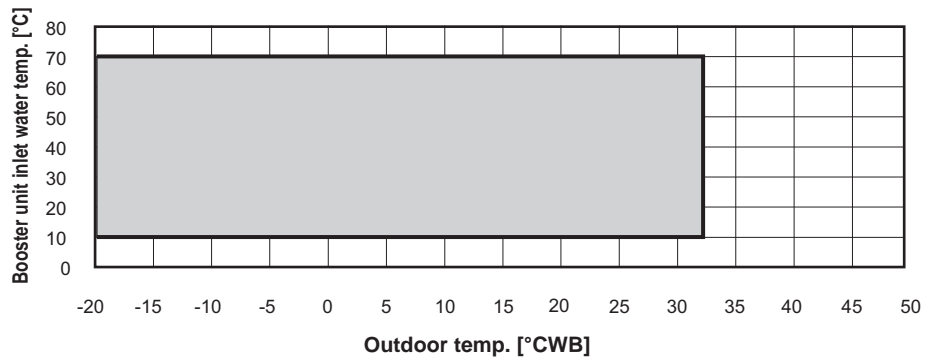

WR2-Series

Heating

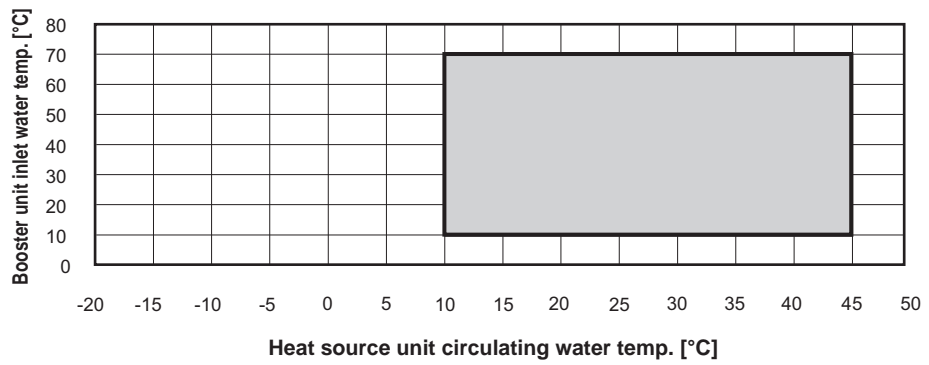

PWFY-EP100VM-E1-AU, PWFY-EP100VM-E2-AU
Y-Series, Y-Series (High efficiency)

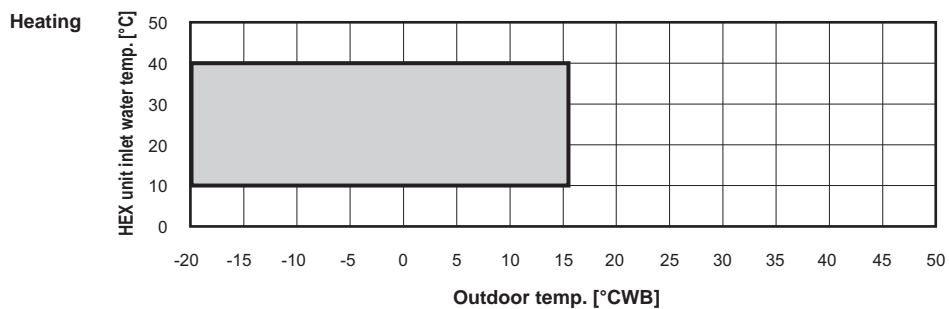

WY-Series, WR2-Series

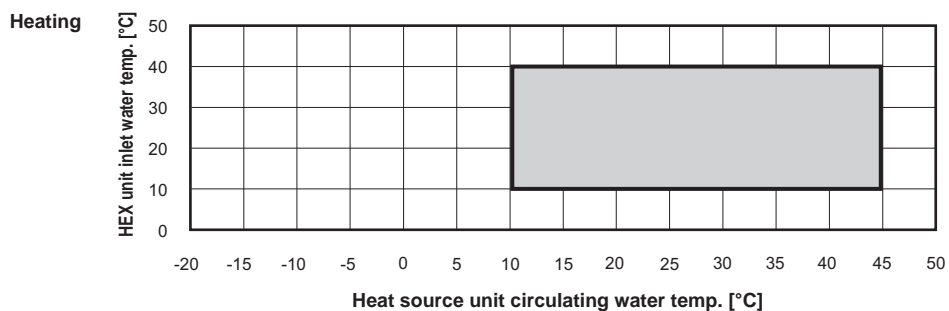

R2-Series, R2-Series (High efficiency)

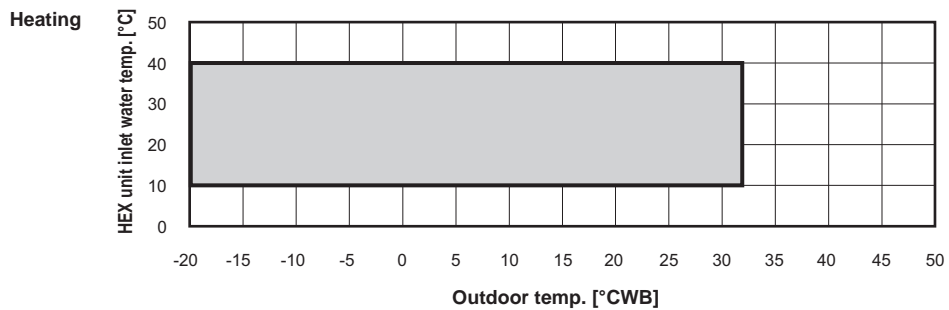

PWFY-P-VM-E-BU, EP-VM-E1-AU, EP-VM-E2-AU

Y-Series, Y-Series (High efficiency), R2-Series, R2-Series (High efficiency)

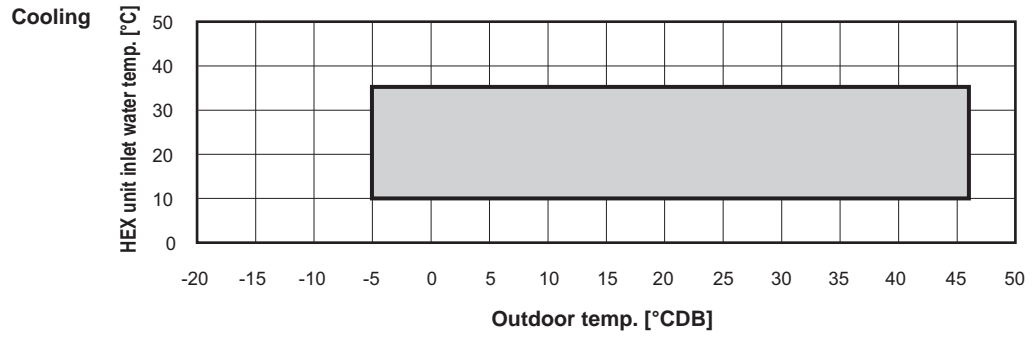

WY-Series, WR2-Series

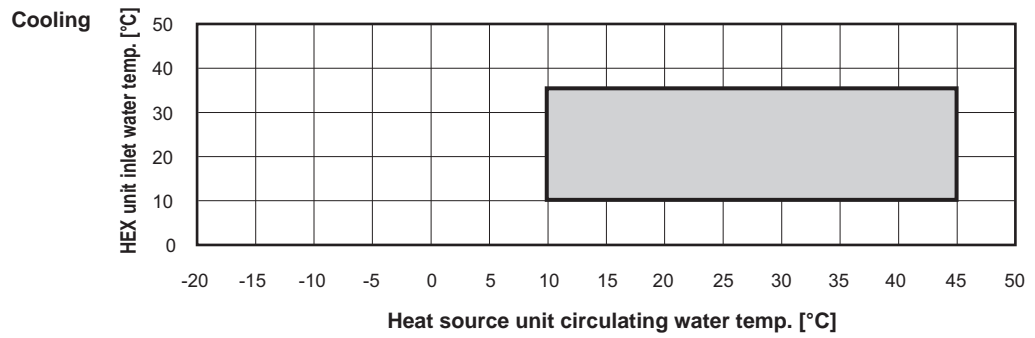

ZUBADAN-Series

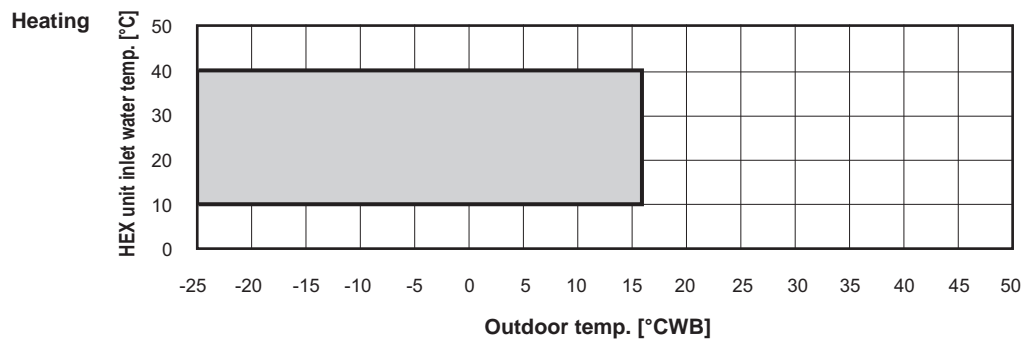

ZUBADAN-Series

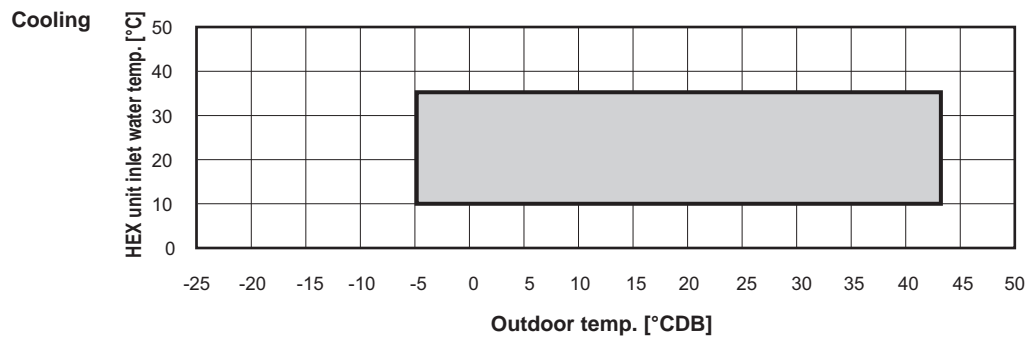

9-1. Correction by temperature

Estimated performance without defrost
 R2-Series/R2-Series (High efficiency) + PWFY-P100VM-E-BU

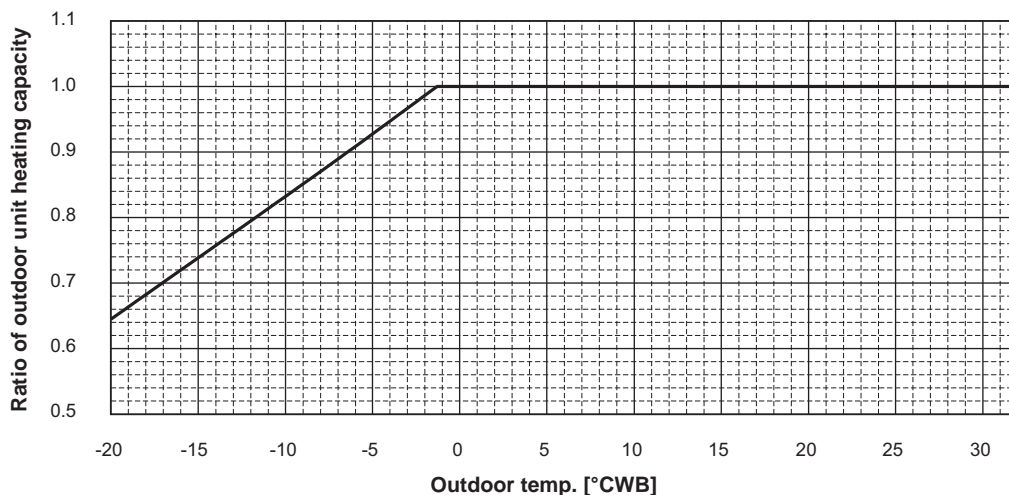
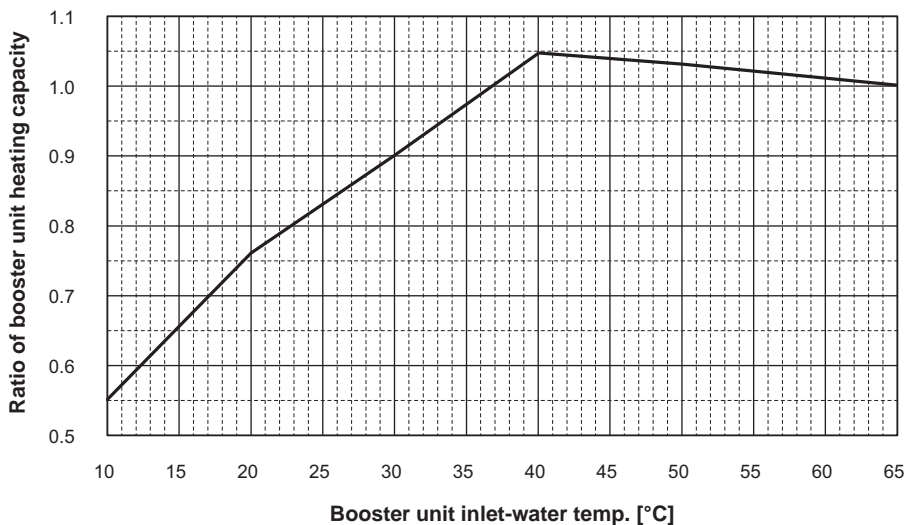

PWFY-P-VM-E-BU,EP-VM-E1-AU, EP-VM-E2-AU

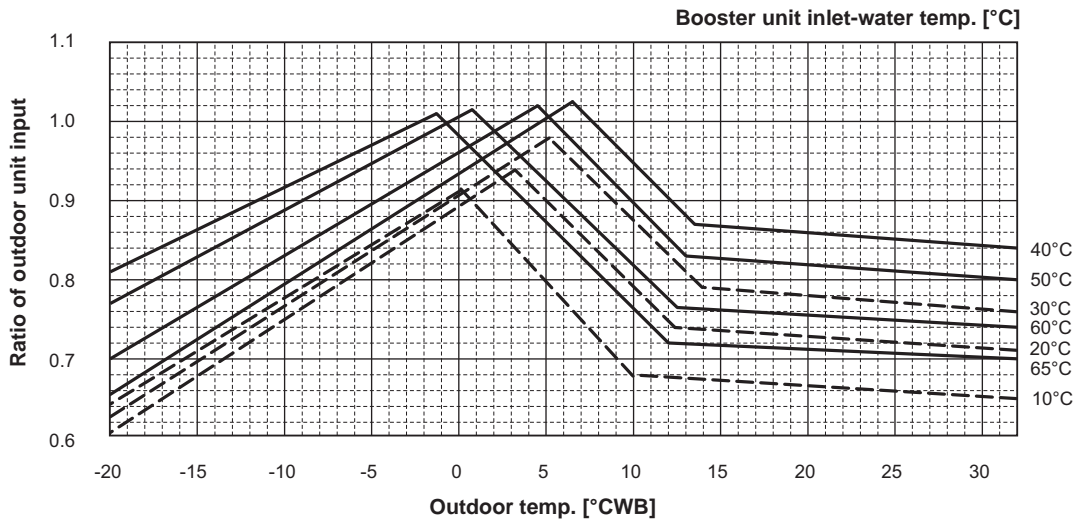
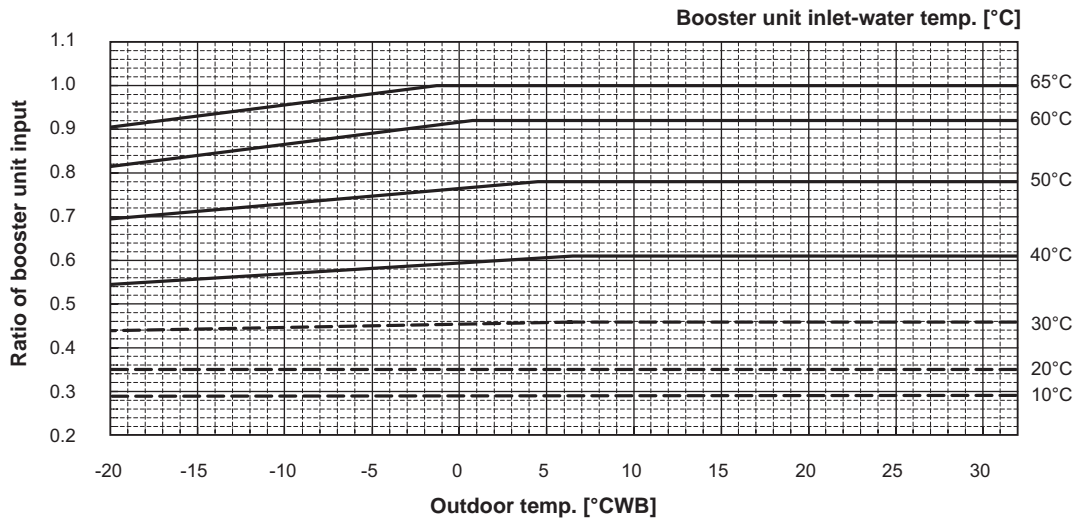

R2-Series

HP	8	10	12	14	16	18	20	22	24	26	28	30	32	34	36	38	40	42	44
Nominal Input (kW)	5.49	7.32	9.37	11.59	11.42	14.93	16.06	20.29	19.12	20.68	22.68	23.01	22.84	26.23	30.13	34.04	36.38	38.82	42.42

R2-Series (High efficiency)

HP	8	10	12	14	16	18	20	22	24	26	28	30	32	34	36	38	40	42	44
Nominal Input (kW)	6.41	8.45	9.97	12.93	13.40	15.86	19.54	19.71	20.34	22.51	25.28	26.38	26.80	29.75	32.01	33.01	36.07	38.15	41.17

* The nominal input values for outdoor units above are referential values for a system in which the PWFY units are connected to the outdoor units to its 100% capacity. The actual calculation results of the corrected input of the outdoor unit depend on the ratio of PWFY and other types of indoor units connected. Use the nominal input values above for the PWFY units when calculating the corrected input.

R2-Series/R2-Series (High efficiency) + PWFY-P100VM-E-BU + WCB Energy saving mode*
 *For energy saving mode, set WCB DIP SW 6-5 ON.

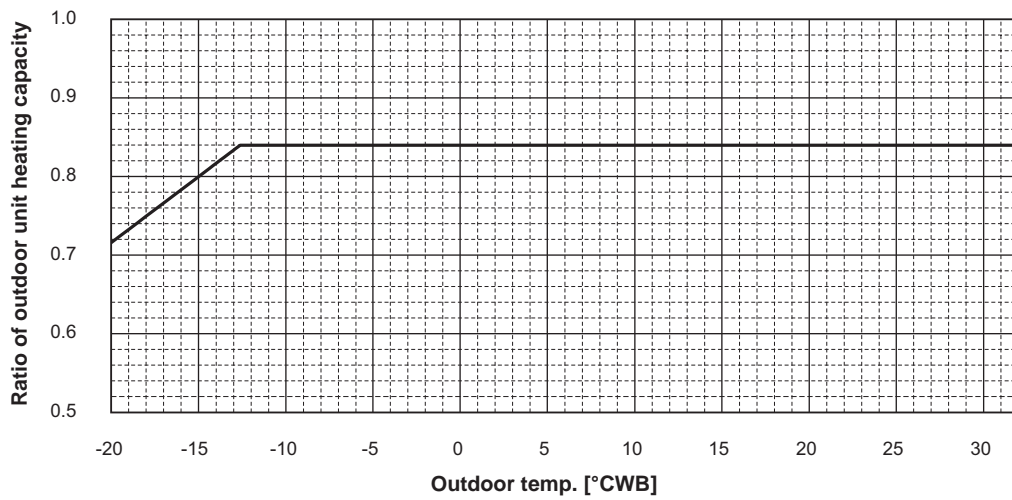
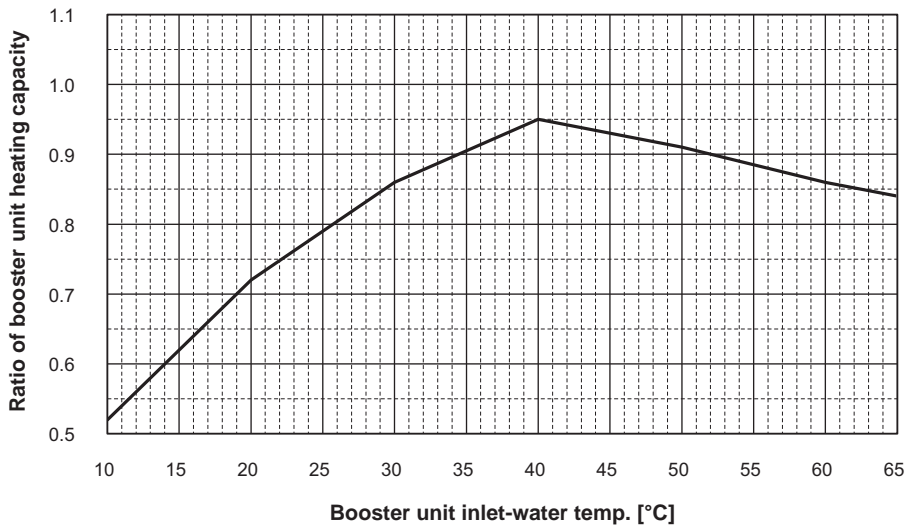

PWFY-P-VM-E-BU, EP-VM-E1-AU, EP-VM-E2-AU

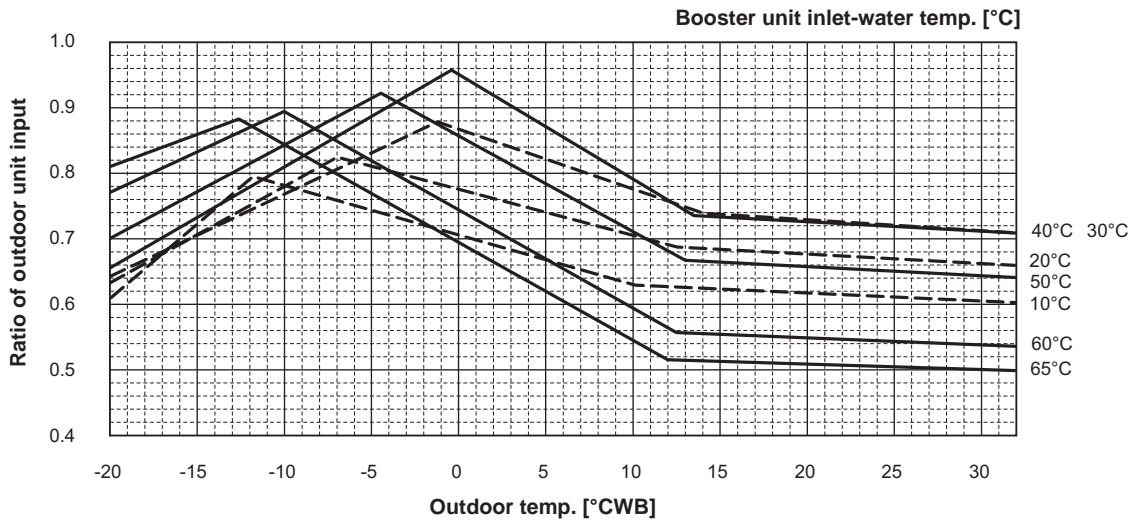
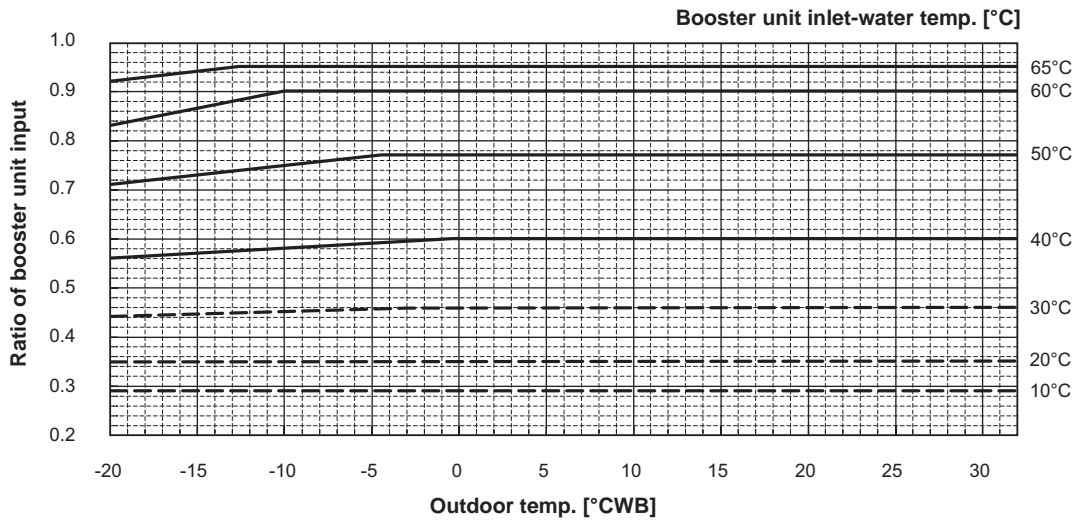

R2-Series

HP	8	10	12	14
Nominal Input (kW)	5.49	7.32	9.37	11.59

R2-Series (High efficiency)

HP	8	10	12	14
Nominal Input (kW)	6.41	8.45	9.97	12.93

* The nominal input values for outdoor units above are referential values for a system in which the PWFY units are connected to the outdoor units to its 100% capacity. The actual calculation results of the corrected input of the outdoor unit depend on the ratio of PWFY and other types of indoor units connected. Use the nominal input values above for the PWFY units when calculating the corrected input.

Y-Series + PWFY-EP100VM-E1-AU, PWFY-EP100VM-E2-AU

Heating

PWFY-P-VM-E-BU, EP-VM-E1-AU, EP-VM-E2-AU

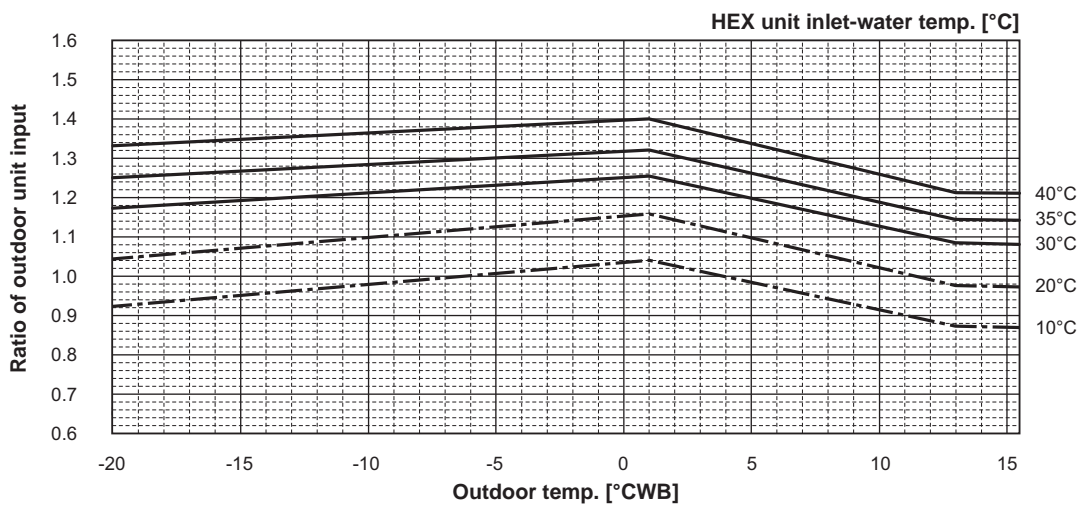
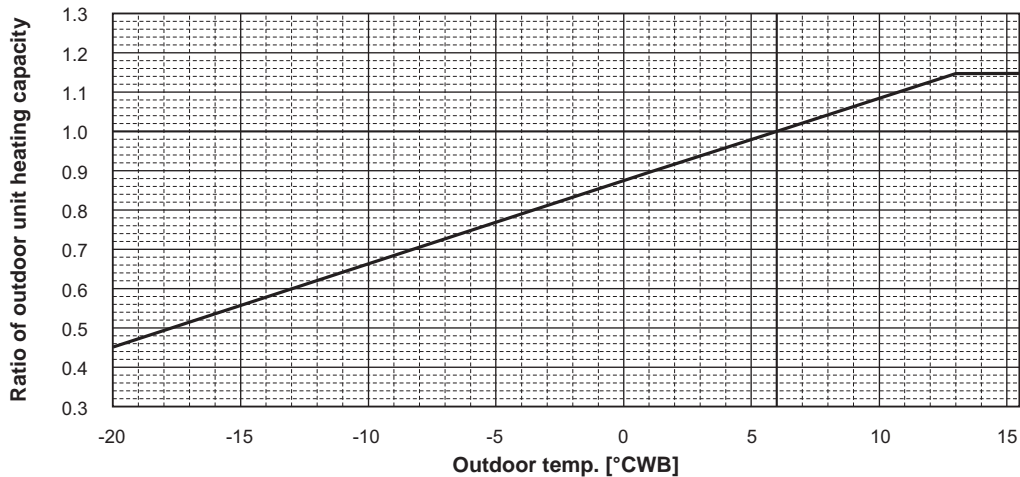
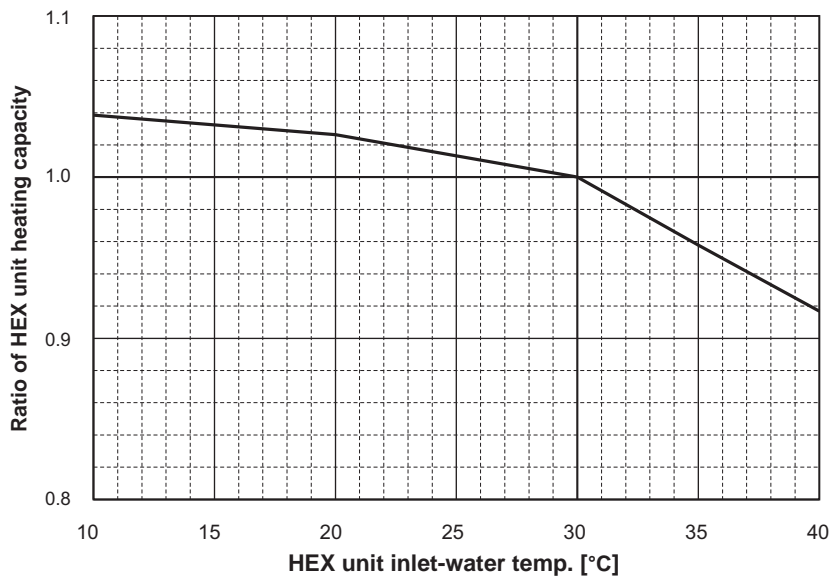

--- * The dashed lines show the reference values obtained from using the simulation.

HP	8	10	12	14	16	18	20	22	24	26	28	30	32	34	36	38	40	42	44	46	48	50	52	54
Nominal Input (kW)	5.81	7.34	9.07	11.13	12.50	15.55	18.52	17.29	19.36	21.00	22.97	24.93	27.62	29.90	33.00	30.40	32.70	34.25	36.60	39.29	40.76	44.08	46.04	49.12

* The nominal input values for outdoor units above are referential values for a system in which the PWFY units are connected to the outdoor units to its 100% capacity. The actual calculation results of the corrected input of the outdoor unit depend on the ratio of PWFY and other types of indoor units connected. Use the nominal input values above for the PWFY units when calculating the corrected input.

Cooling

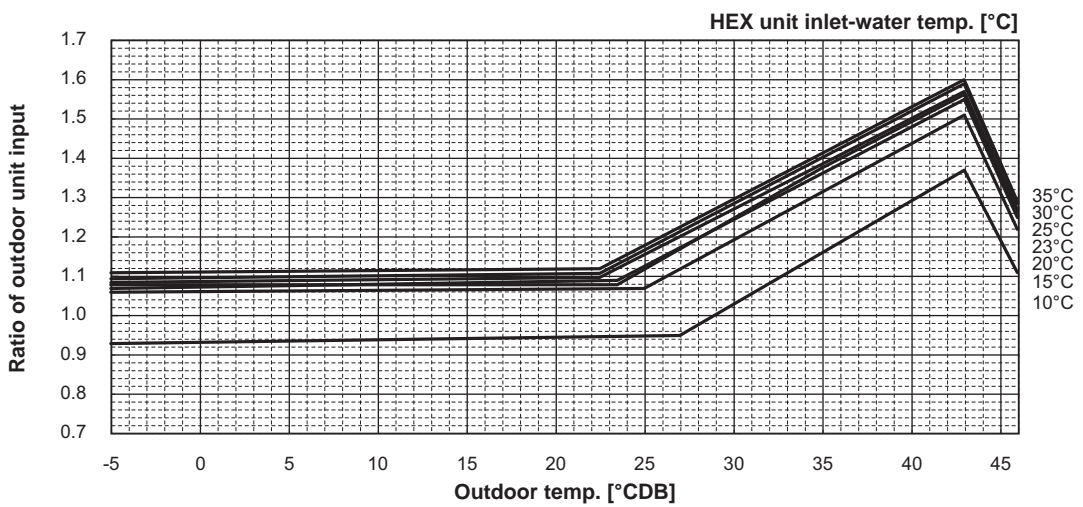
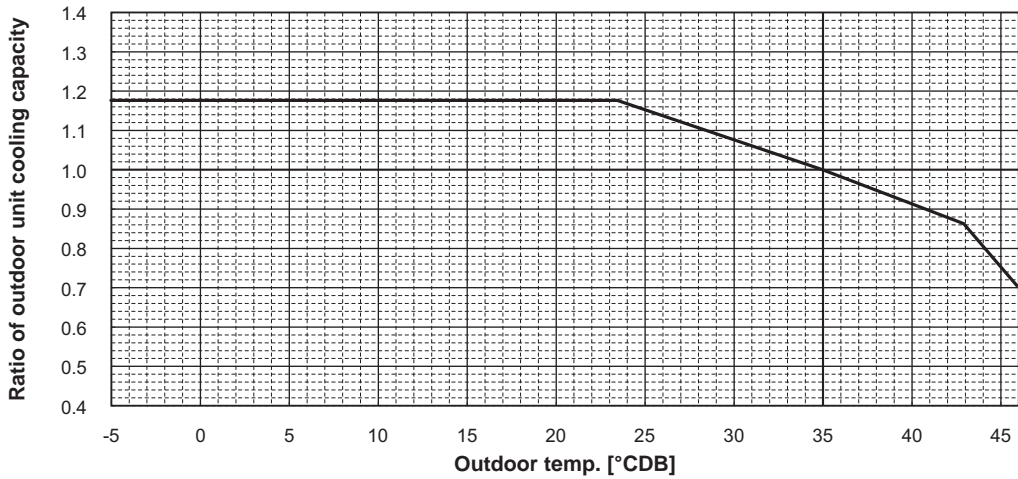
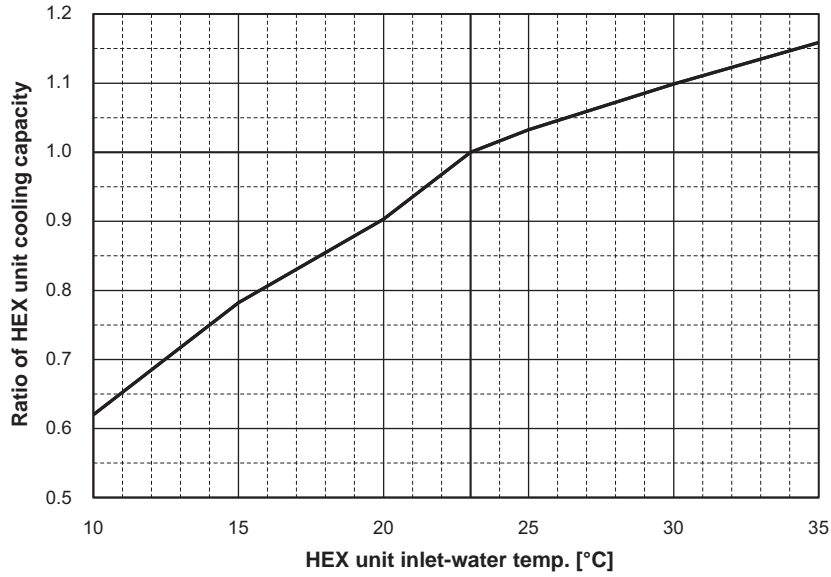

HP	8	10	12	14	16	18	20	22	24	26	28	30	32	34	36	38	40	42	44	46	48	50	52	54
Nominal Input (kW)	5.19	6.88	8.56	11.69	13.55	14.79	18.39	16.66	19.43	20.97	24.69	26.56	27.86	30.18	31.46	30.25	32.10	35.01	38.62	40.24	44.10	43.80	47.80	47.40

* The nominal input values for outdoor units above are referential values for a system in which the PWFY units are connected to the outdoor units to its 100% capacity. The actual calculation results of the corrected input of the outdoor unit depend on the ratio of PWFY and other types of indoor units connected. Use the nominal input values above for the PWFY units when calculating the corrected input.

Y-Series (High efficiency) + PWFY-EP100VM-E1-AU, PWFY-EP100VM-E2-AU

Heating

PWFY-P-VM-E-BU,EP-VM-E1-AU, EP-VM-E2-AU

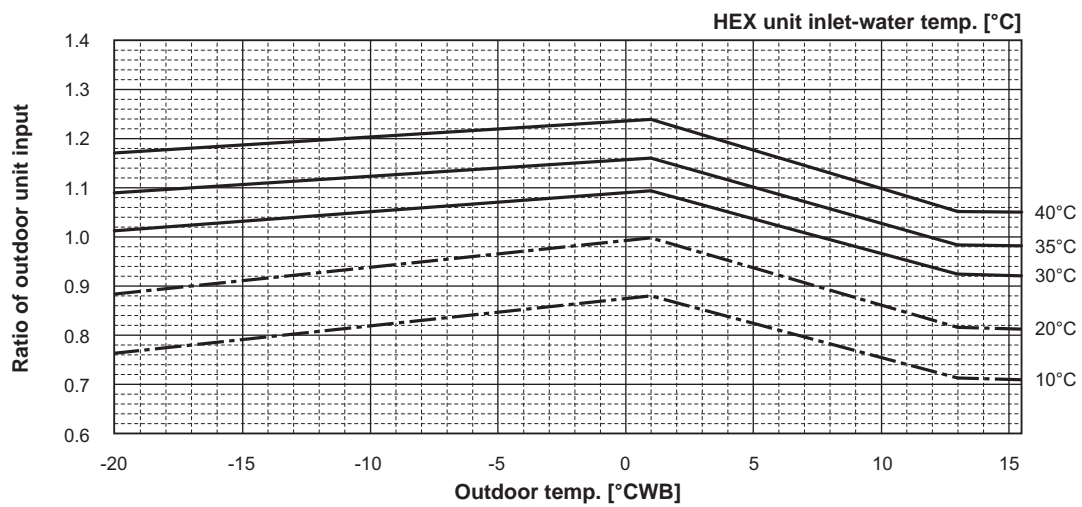
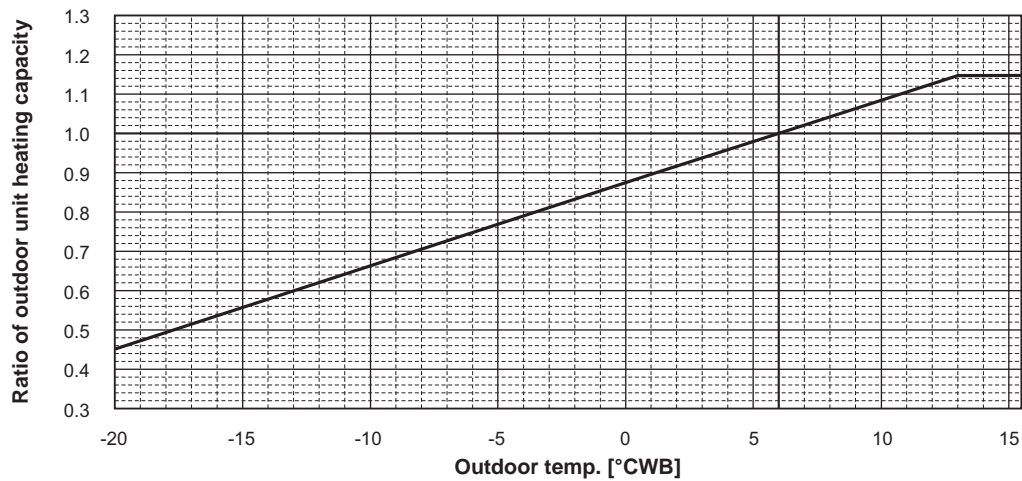
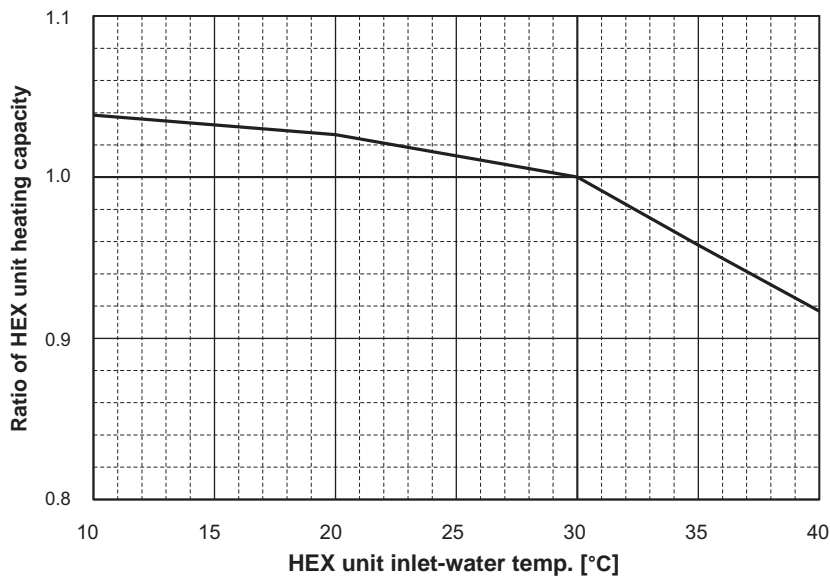

--- * The dashed lines show the reference values obtained from using the simulation.

HP	8	10	12	14	16	18	20	22	24	26	28	30	32	34	36	38	40	42	44	46	48	50	52	54
Nominal Input (kW)	5.73	7.68	9.16	12.53	13.15	16.09	19.68	17.73	19.66	20.07	21.67	23.92	25.18	27.76	29.04	32.03	33.50	36.87	41.17	44.47	45.45	49.36	50.62	54.36

* The nominal input values for outdoor units above are referential values for a system in which the PWFY units are connected to the outdoor units to its 100% capacity. The actual calculation results of the corrected input of the outdoor unit depend on the ratio of PWFY and other types of indoor units connected. Use the nominal input values above for the PWFY units when calculating the corrected input.

Cooling

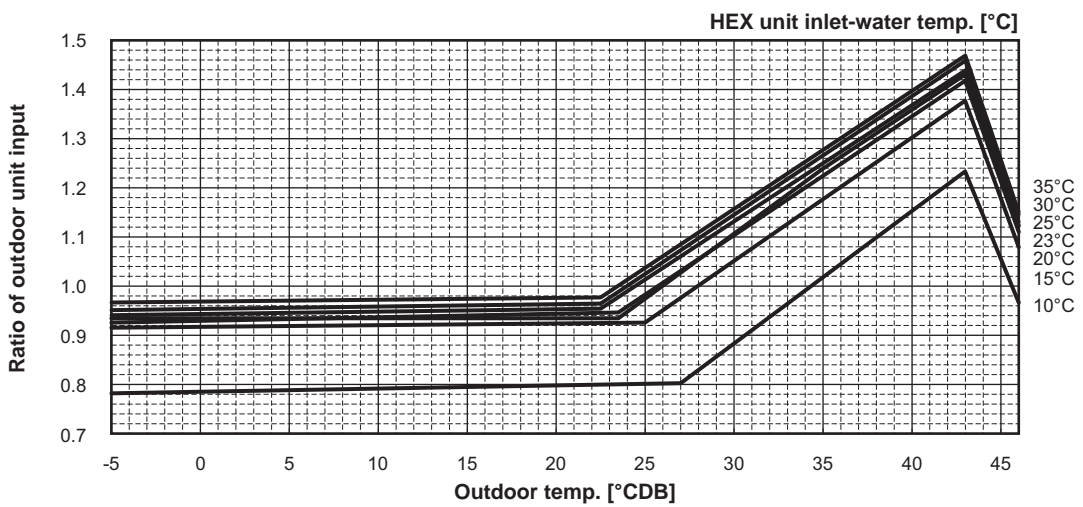
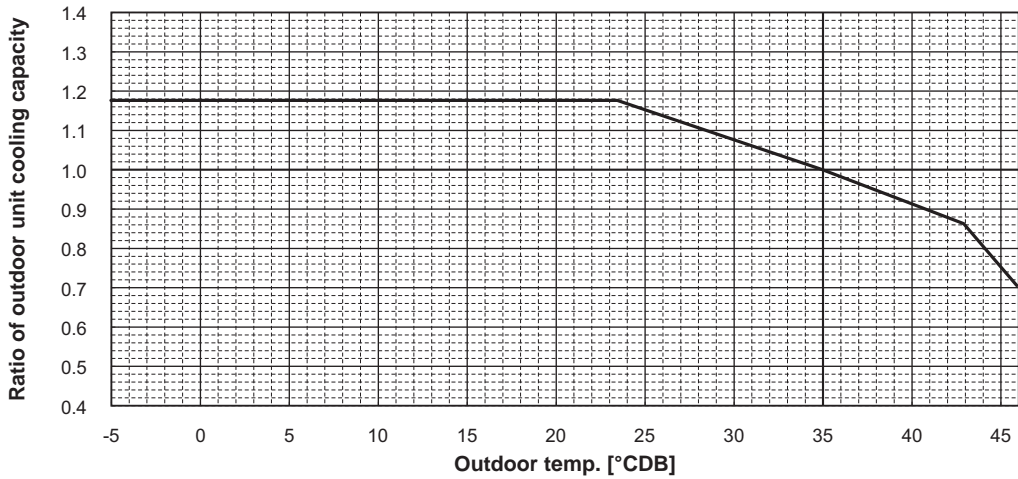
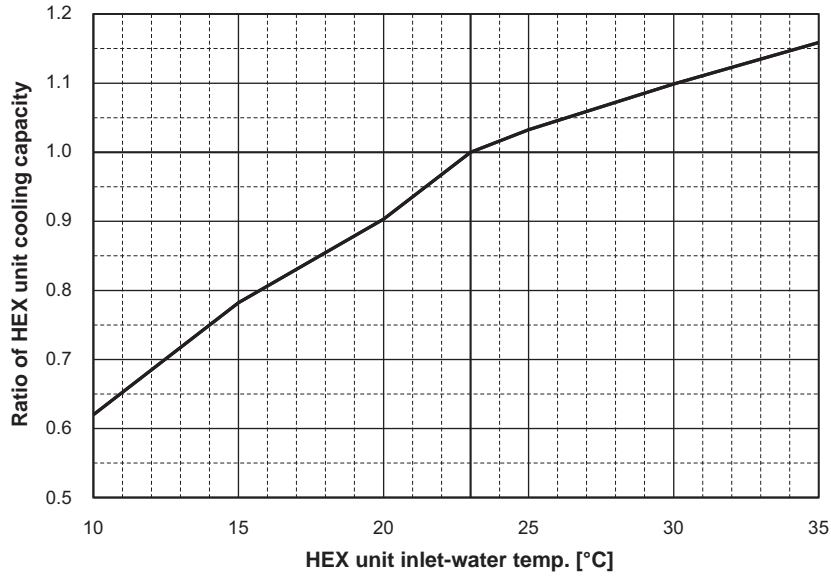

HP	8	10	12	14	16	18	20	22	24	26	28	30	32	34	36	38	40	42	44	46	48	50	52	54
Nominal Input (kW)	5.19	6.89	8.56	11.69	12.26	14.79	18.72	16.62	18.59	18.15	20.15	21.85	23.43	25.53	27.22	30.33	31.04	34.40	38.15	41.53	42.76	45.90	46.94	50.00

* The nominal input values for outdoor units above are referential values for a system in which the PWFY units are connected to the outdoor units to its 100% capacity. The actual calculation results of the corrected input of the outdoor unit depend on the ratio of PWFY and other types of indoor units connected. Use the nominal input values above for the PWFY units when calculating the corrected input.

R2-Series + PWFY-EP100VM-E1-AU, PWFY-EP100VM-E2-AU

Heating

PWFY-P-VM-E-BU,EP-VM-E1-AU, EP-VM-E2-AU

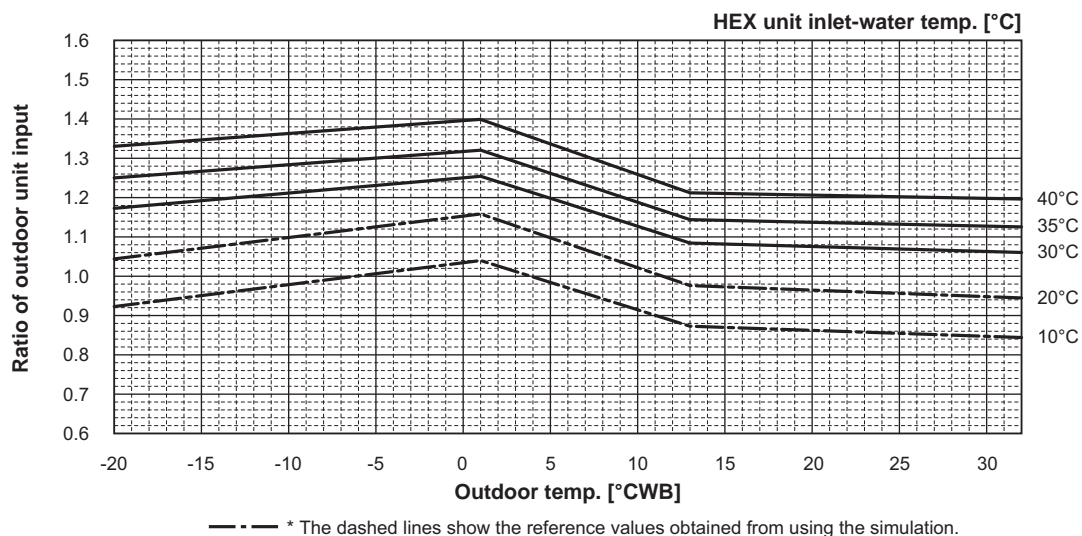
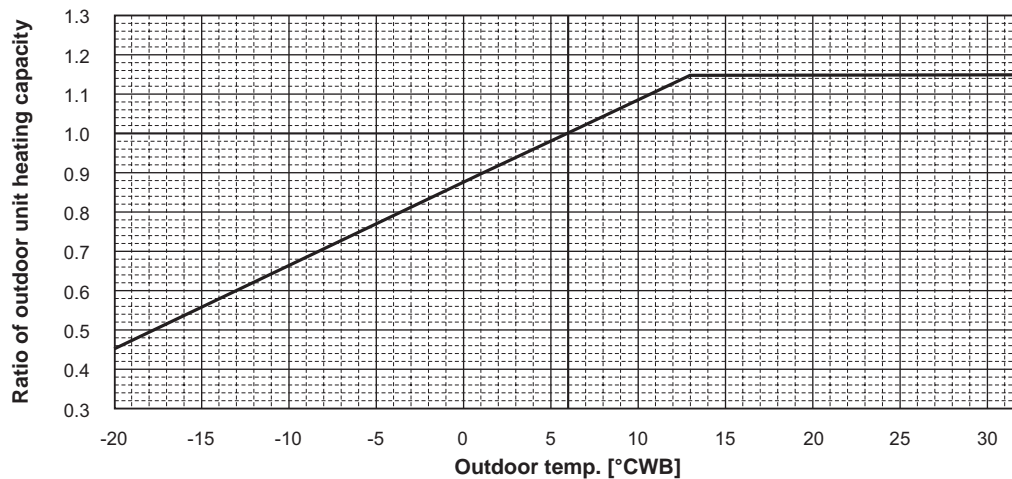
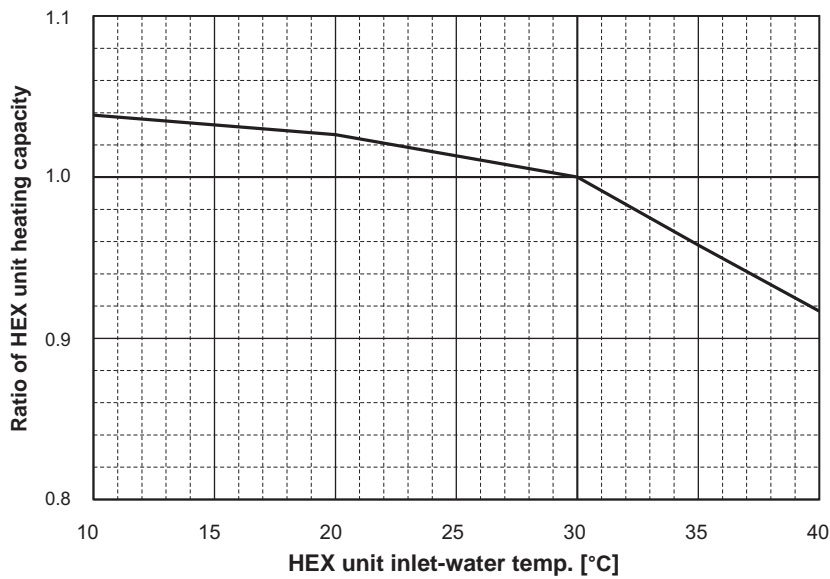

HP	8	10	12	14	16	18	20	22	24	26	28	30	32	34	36	38	40	42	44
Nominal Input (kW)	5.49	7.32	9.37	11.59	11.42	14.93	16.06	20.29	19.12	20.68	22.68	23.01	22.84	26.23	30.13	34.04	36.38	38.82	42.42

* The nominal input values for outdoor units above are referential values for a system in which the PWFY units are connected to the outdoor units to its 100% capacity. The actual calculation results of the corrected input of the outdoor unit depend on the ratio of PWFY and other types of indoor units connected. Use the nominal input values above for the PWFY units when calculating the corrected input.

Cooling

PWFY-P-VM-E-BU,EP-VM-E1-AU, EP-VM-E2-AU

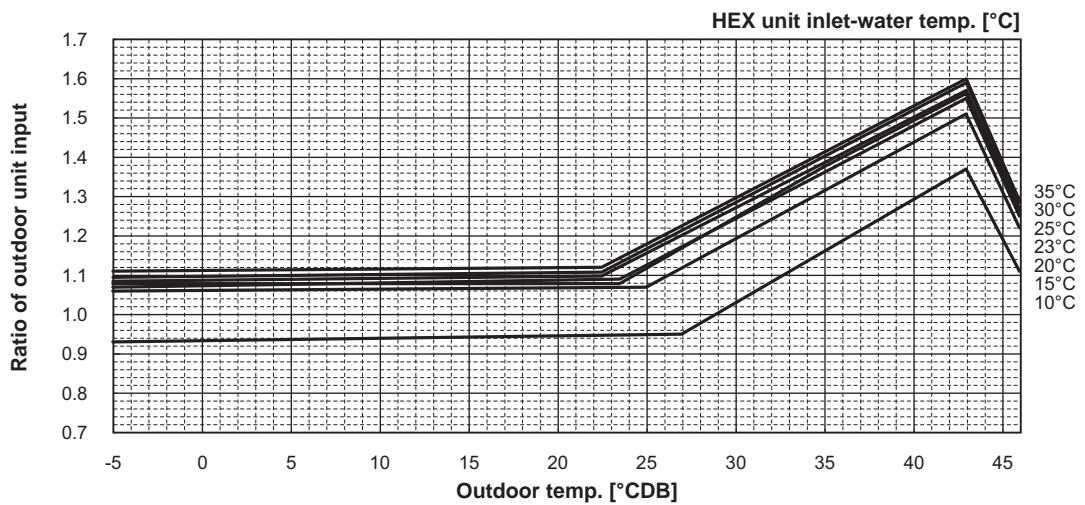
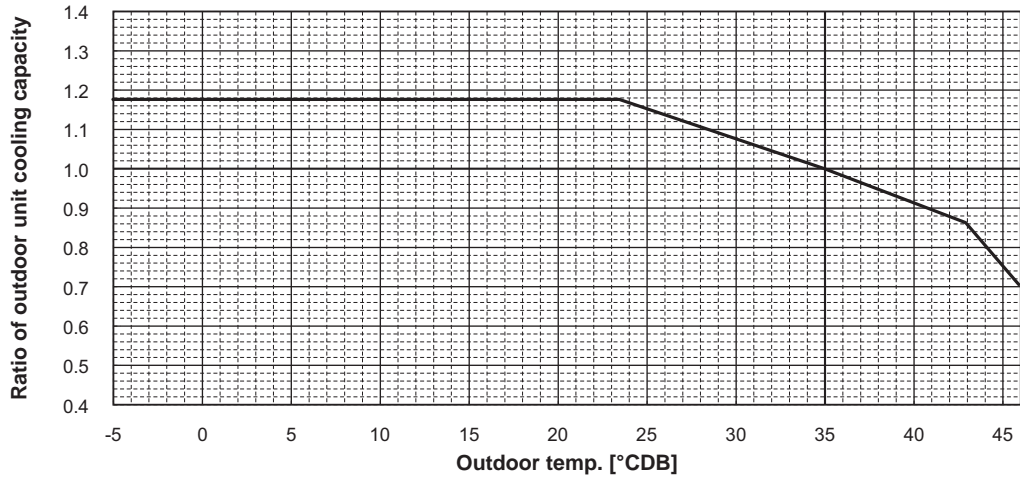
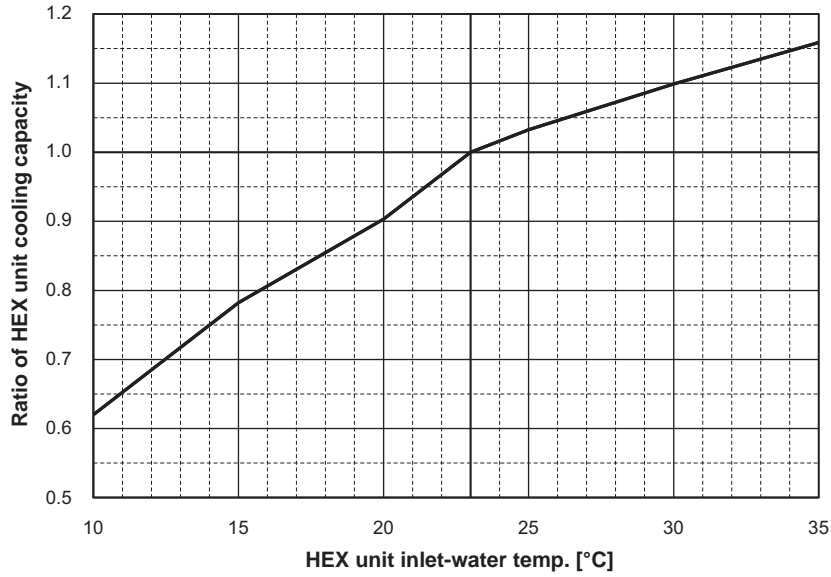

HP	8	10	12	14	16	18	20	22	24	26	28	30	32	34	36	38	40	42	44
Nominal Input (kW)	5.29	6.98	9.10	11.76	13.71	14.32	17.77	22.18	19.32	21.28	24.24	26.23	28.30	29.26	29.79	34.83	38.56	41.54	45.09

* The nominal input values for outdoor units above are referential values for a system in which the PWFY units are connected to the outdoor units to its 100% capacity. The actual calculation results of the corrected input of the outdoor unit depend on the ratio of PWFY and other types of indoor units connected. Use the nominal input values above for the PWFY units when calculating the corrected input.

R2-Series (High efficiency) + PWFY-EP100VM-E1-AU, PWFY-EP100VM-E2-AU

Heating

PWFY-P-VM-E-BU,EP-VM-E1-AU, EP-VM-E2-AU

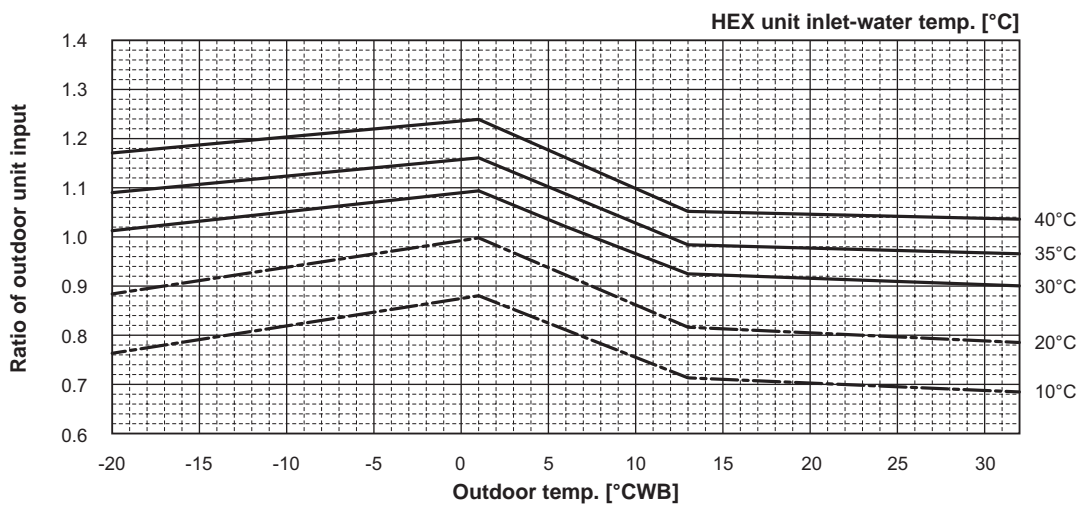
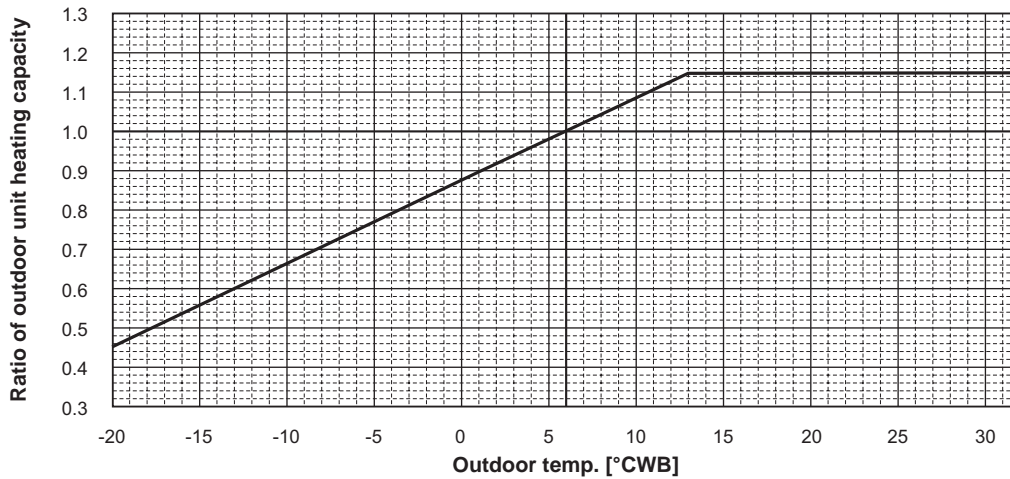
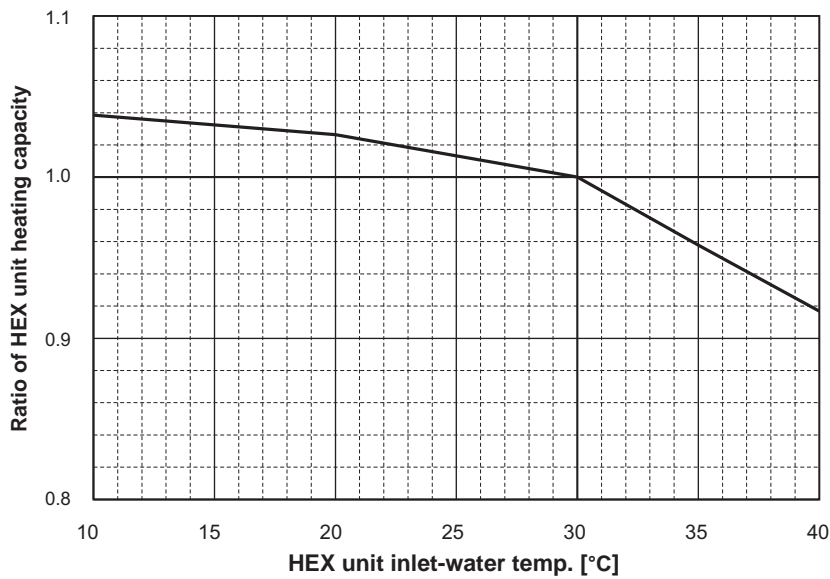

--- * The dashed lines show the reference values obtained from using the simulation.

HP	8	10	12	14	16	18	20	22	24	26	28	30	32	34	36	38	40	42	44
Nominal Input (kW)	6.41	8.45	9.97	12.93	13.40	15.86	19.54	19.71	20.34	22.51	25.28	26.38	26.80	29.75	32.01	33.01	36.07	38.15	41.17

* The nominal input values for outdoor units above are referential values for a system in which the PWFY units are connected to the outdoor units to its 100% capacity. The actual calculation results of the corrected input of the outdoor unit depend on the ratio of PWFY and other types of indoor units connected. Use the nominal input values above for the PWFY units when calculating the corrected input.

Cooling

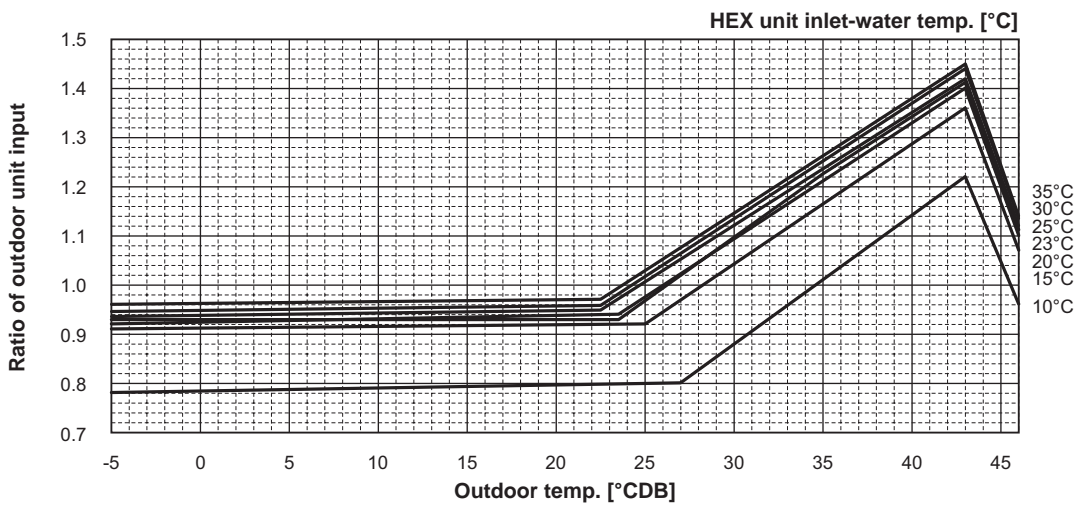
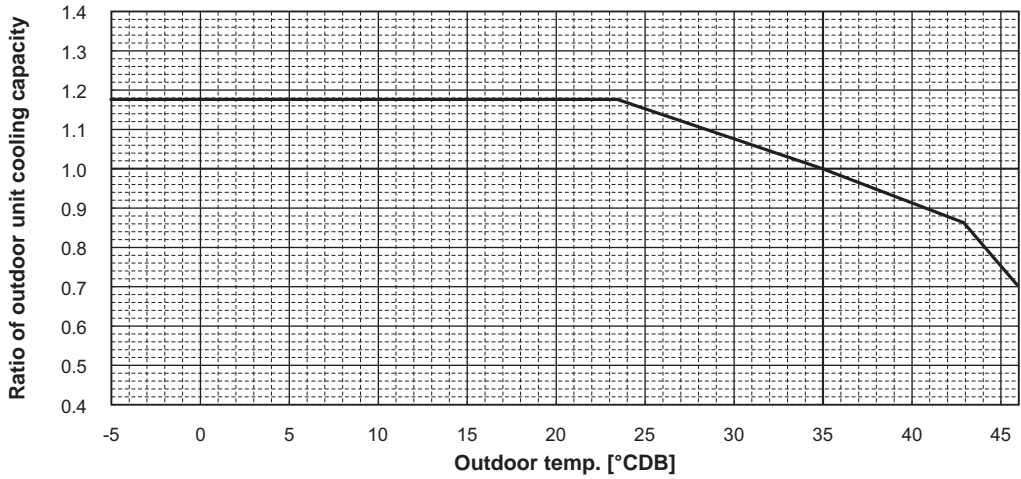
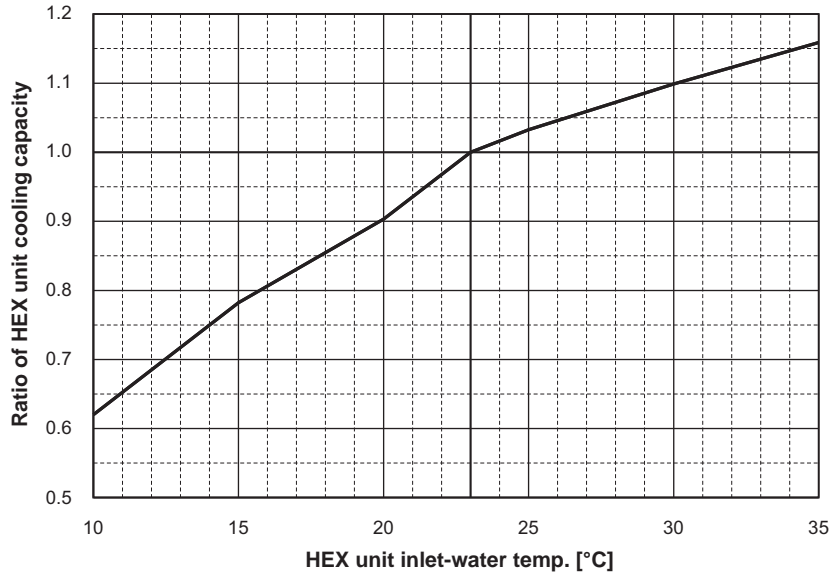

HP	8	10	12	14	16	18	20	22	24	26	28	30	32	34	36	38	40	42	44
Nominal Input (kW)	5.48	7.25	9.20	12.57	12.56	14.83	18.30	22.00	19.54	22.12	25.97	25.99	25.93	28.48	30.98	33.23	37.66	40.83	44.76

* The nominal input values for outdoor units above are referential values for a system in which the PWFY units are connected to the outdoor units to its 100% capacity. The actual calculation results of the corrected input of the outdoor unit depend on the ratio of PWFY and other types of indoor units connected. Use the nominal input values above for the PWFY units when calculating the corrected input.

9-2. Correction by total indoor

Total capacity of PWFY-(E)P100VM-E(1, 2)-BU/AU

PWFY-P-VM-E-BU, EP-VM-E1-AU, EP-VM-E2-AU

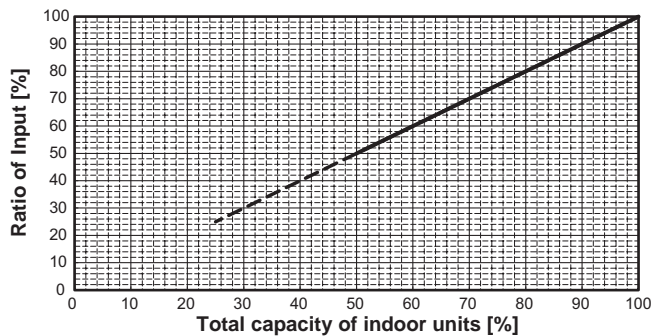
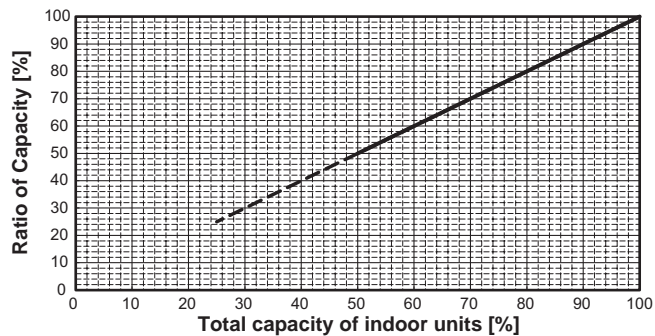

Note Out of warranty at 50% or less due to unit's turn on-off.

9-3. Correction by water volume

PWFY-P100VM-E-BU

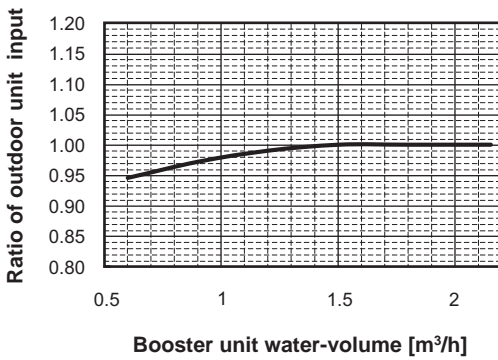
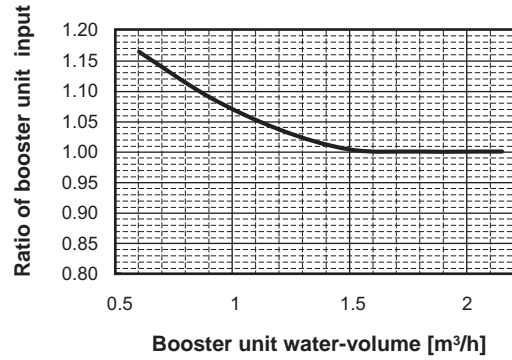
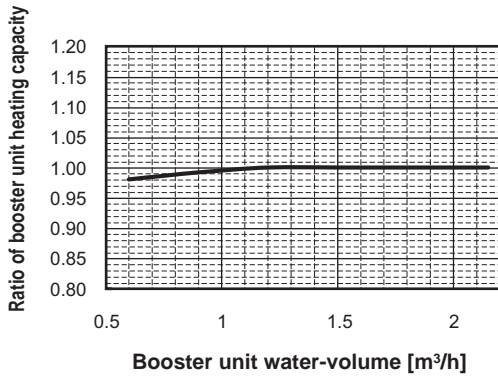

PWFY-EP100VM-E1-AU, PWFY-EP100VM-E2-AU

Heating

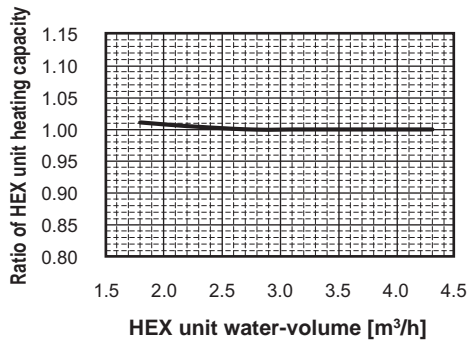

Cooling

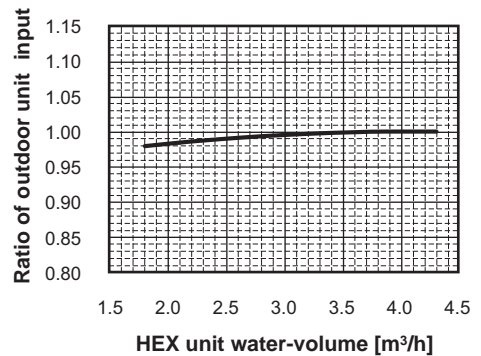
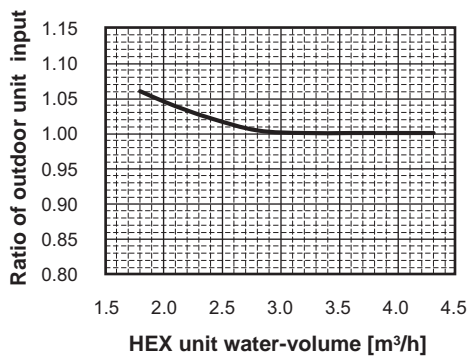
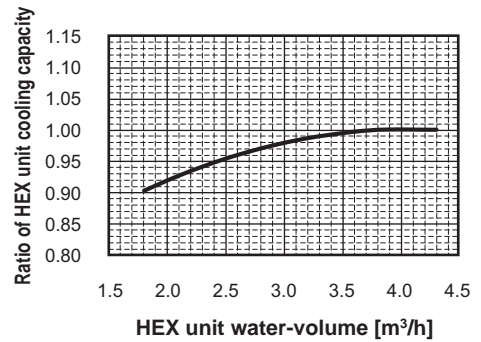

9-4. Water pressure drop

PWFY-P100VM-E-BU (with strainer)

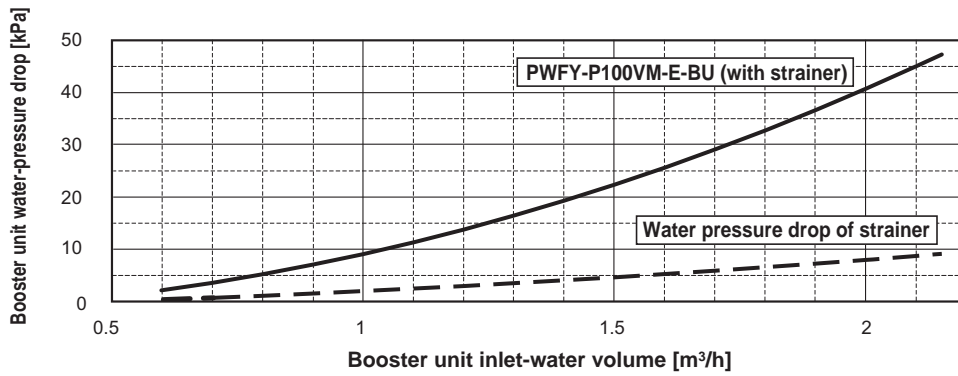

PWFY-EP100VM-E1-AU, PWFY-EP100VM-E2-AU (with strainer)

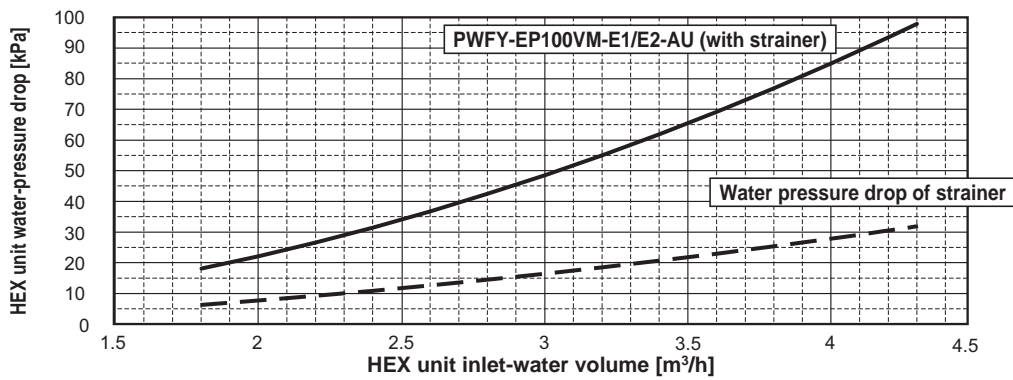

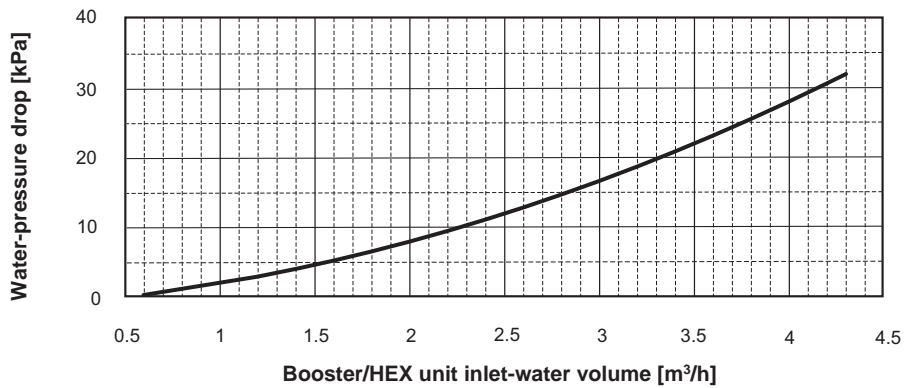

9-5. Water pressure drop of Strainer only

accessory for PWFY-P100VM-E-BU and PWFY-EP100VM-E1,E2-AU

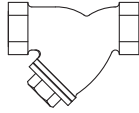
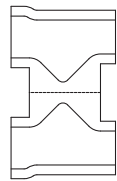
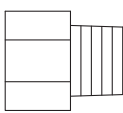
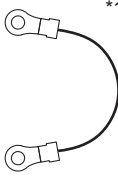
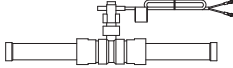

PWFY-P-VM-E-BU,EP-VM-E1-AU, EP-VM-E2-AU

PWFY

(A) Strainer	(B) Heat insulation material	(C) Expansion joint X2	(D) Wire	(E) Flow switch	(F) Buffer material
		 *2	 *1	 *2	 *2

*1. PWFY-P100VM-E-BU only
 *2. PWFY-EP100VM-E1/E2-AU only

- (A) Install the strainer at the water pipe inlet.
- (B) This insulation is for exclusive use with the strainer. Wrap the strainer with the insulation after water pipes are installed.
- (C) Install them at the strainer inlet. Refer to P58 for details.
- (D) To perform test run before the pump interlock circuit is completed, short circuit the terminal block TB142A (IN1), and then perform test run.
- (E) When installing the unit, be sure to install the supplied flow switch on the water outlet side of the unit and connect the wire to IN1 of TB142A on the unit.
- (F) If allowing wires inside the unit to hang loosely so as to prevent water from collecting and running down into electrical components, be careful not to let the wires hang so loosely as to come into contact with nearby piping (solenoid valves). If there is any risk of contact being made, use the included buffer material to protect other components.

CMB-PW202V-J

SIZE	Unit
ODø19.05 - IDø15.88	2
ODø22.2 - IDø19.05	1
ODø15.88 - IDø9.52	1
ODø15.88 - IDø12.7	1
ODø25.4 - IDø19.05	1
ODø25.4 - IDø22.2	1
ODø19.05 - IDø22.2	1
ODø25.4 - IDø28.6	1
ODø22.2 - IDø28.6	1
ODø25.4 - IDø15.88	1
Drain hose set	1 set
Installation Manual	1

11-1. Solenoid valve kit

PAC-SV01PW-E (For PWFY-EP100VM-E1-AU *1)

Unit: mm

PWFY-P-VM-E-BU, EP-VM-E1-AU, EP-VM-E2-AU

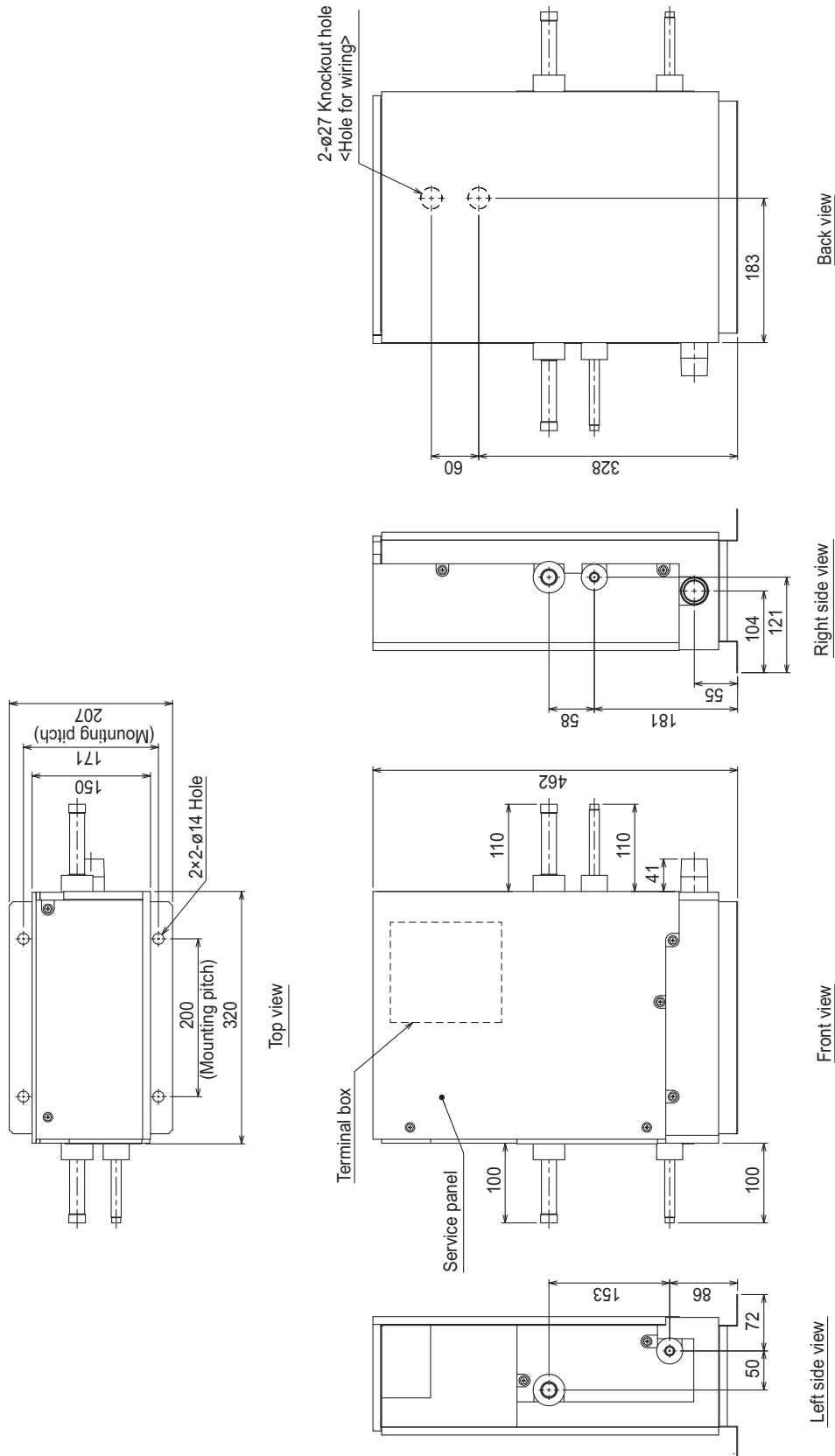

*1 PWFY-EP100VM-E2-AU do not need PAC-SV01PW-E because they are built in with the same functions.

11-2. Remote controller

PAR-W21MAA specifications

Item	Description	Operations	Display
ON/OFF	Runs and stops the operation of a group of units	○	○
Operation mode switching	Switches between Hot Water / Heating / Heating ECO / Anti-freeze / Cooling * Available operation modes vary depending on the unit to be connected. * Switching limit setting can be made via a remote controller.	○	○
Water temperature setting	Temperature can be set within the ranges below. (in increments of 1°C or 1°F) Hot Water 30°C ~ 70°C Heating 30°C ~ 40°C*1 (Dip SW1-1 = OFF) , 30°C ~ 45°C (Dip SW1-1 = ON) Heating ECO 30°C ~ 40°C*1 (Dip SW1-1 = OFF) , 30°C ~ 45°C (Dip SW1-1 = ON) Anti-freeze 30°C ~ 40°C*1 (Dip SW1-1 = OFF) , 10°C ~ 45°C (Dip SW1-1 = ON) Cooling 10°C ~ 30°C *1. The maximum temperature setting is 45°C in case of PWFY Ver.1.24 or earlier. * The settable range varies depending on the unit to be connected.	○	○
Preset temperature range	Preset temperature range setting can be limited via a remote controller.	○	○
Water temperature display	10°C ~ 90°C (in increments of 1°C or 1°F) * The settable range varies depending on the unit to be connected.	×	○
Permit / Prohibit local operation	Individually prohibits operations of each local remote control function :ON/OFF, Operation modes,water temperature setting, Circulating water replacement warning reset. * Upper level controller may not be connected depending on the unit to be connected.	×	○
Weekly scheduler	ON / OFF / Water temperature setting can be done up to 6 times one day in the week. (in increments of a minute)	○	○
Error	When an error is currently occurring on a unit, the afflicted unit and the error code are displayed.	×	○
Self check (Error history)	Searches the latest error history by pressing the CHECK button twice.	○	○
Test run	Enables the Test run mode by pressing the TEST button twice. * Test run mode is not available depending on the unit to be connected.	○	○
Circulating water replacement warning	Displays the circulating water replacement warning via the unit message. Clears the display by pressing the CIR.WATER button twice. * Circulating water replacement warning is not available depending on the unit to be connected.	○	○
LANGUAGE setting	The language on the dot matrix LCD can be changed. (Seven languages) English/German/Spanish/Russian/Italian/French/Swedish	○	○
Operation locking function	Remote controller operation can be locked or unlocked. ·All-switch locking ·Locking except ON/OFF switch	○	○

PWFY-P-VM-E-BU, EP-VM-E1-AU, EP-VM-E2-AU

12-1. General cautions

⚠ WARNING

Electrical work should be done by qualified electrical engineers in accordance with "Engineering Standards For Electrical Installation" and supplied installation manuals. Special circuits should also be used. If the power circuit lacks capacity or has an installation failure, it may cause a risk of electric shock or fire.

- 1) Be sure to take power from the special branch circuit.
- 2) Be sure to install an earth leakage breaker to the power.
- 3) Install the unit to prevent that any of the control circuit cables (remote controller, transmission cables, or external input/output line) is brought in direct contact with the power cable outside the unit.
- 4) Ensure that there is no slack on all wire connections.
- 5) Some cables (power, remote controller, transmission cables external input/output line) above the ceiling may be bitten by mouses. Use as many metal pipes as possible to insert the cables into them for protection.
- 6) Never connect the power cable to leads for the transmission cables. Otherwise the cables would be broken.
- 7) Be sure to connect control cables to the indoor unit, remote controller, and the outdoor unit.
- 8) Be sure to ground the unit.
- 9) Select control cables from the conditions given in P43.

⚠ CAUTION

Be sure to put the unit to the ground on the outdoor unit side. Do not connect the earth cable to any gas pipe, water pipe, lightning rod, or telephone earth cable. Incomplete grounding may cause a risk of electric shock.

12-2. Power supply for PWFY unit

Electrical characteristics of PWFY unit

- Power supply cords of appliances shall not be lighter than design 245 IEC 57 or 227 IEC 57.
- A switch with at least 3 mm contact separation in each pole shall be provided by the Air conditioner installation.

Model	Power supply				Compressor		RLA (A)
	Hz	Volts	Voltage range	MCA (A)	Output (kW)	SC (A)	Heating
PWFY-P100VM-E-BU	50/60	220-230-240 V	Max. 264 V Min. 198 V	15.71	1.0	1.25	11.63-11.12-10.66

Model	Power supply				RLA (A)	
	Hz	Volts	Voltage range	MCA (A)	Cooling	Heating
PWFY-EP100VM-E1-AU	50/60	220-230-240 V	Max. 264 V Min. 198 V	0.085	0.068-0.065-0.063	

Model	Power supply				RLA (A)	
	Hz	Volts	Voltage range	MCA (A)	Cooling	Heating
PWFY-EP100VM-E2-AU	50/60	220-230-240 V	Max. 264 V Min. 198 V	0.175	0.138-0.139-0.140	

Model	Power supply			RLA (A)	
	Hz	Volts	Voltage range		
PAC-SV01PW-E	50/60	220-230-240 V	Max. 264 V Min. 198 V	0.070-0.074-0.077	

12-3. Power cable specifications

Model	Minimum wire thickness (mm ²)			Breaker for current leakage	Local switch (A)		Breaker for wiring (NFB) (A)
	Main cable	branch	Ground		capacity	fuse	
PWFY-P100VM-E-BU	2.5	-	2.5	30 A 30 mA 0.1 sec or less	25	25	30

Model		Minimum wire thickness (mm ²)			Breaker for current leakage	Local switch (A)		Breaker for wiring (NFB) (A)	
		Main cable	branch	Ground		capacity	fuse		
PWFY-EP100VM-E1-AU PWFY-EP100VM-E2-AU	Total operating current	16 A or less	1.5	1.5	1.5	20A 30mA 0.1 sec. or less	16	16	20
		25 A or less	2.5	2.5	2.5	30A 30mA 0.1 sec. or less	25	25	30
		32 A or less	4.0	4.0	4.0	40A 30mA 0.1 sec. or less	32	32	40

Model	Minimum wire thickness (mm ²)		
	Main cable	branch	Ground
PAC-SV01PW-E	1.5	1.5	1.5

PWFY-P100VM-E-BU

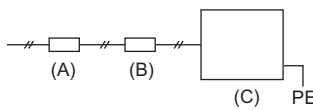

PWFY-EP100VM-E1/E2-AU

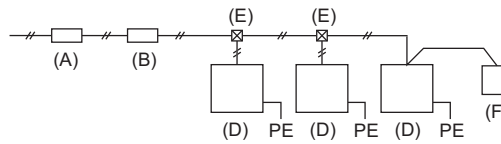

- (A) Breaker for current leakage
- (B) Local switch or breakers for wiring
- (C) PWFY-P100VM-E-BU
- (D) PWFY-EP100VM-E1/E2-AU
- (E) Pull box
- (F) PAC-SV01PW-E

When a solenoid valve kit is connected

- ♦Connect the solenoid valve kit TB2 and PWFY TB2.
- ♦Run the power supply wire through the access hole for power supply wire on the PWFY unit. If the hole is already used to run other wires from the existing PWFY units, use any other wire access holes except the control wire access hole.

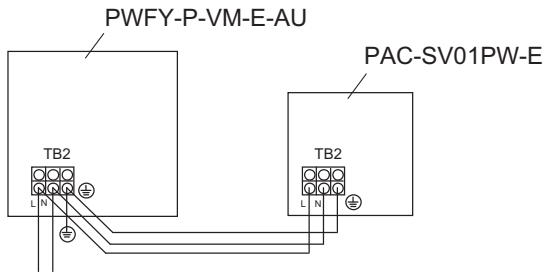

⚠ CAUTION

Do not use anything other than the correct capacity breaker and fuse. Using fuse, wire or copper wire with too large capacity may cause a risk of malfunction or fire.

PW-FY-P-VM-E-BU, EP-VM-E1-AU, EP-VM-E2-AU

12-4. Connecting remote controller, indoor and outdoor transmission cables

- Connect unit TB5 and outdoor unit TB3. (Non-polarized 2-wire (shield))
The "S" on unit TB5 is a shielding wire connection. For specifications about the connecting cables, refer to the outdoor unit installation manual.
- Install a remote controller following the manual supplied with the remote controller.

Power supply examples

Using MA Remote controller (Remote controller is optionally available)

- Connect the "1" and "2" on unit TB15 to a MA remote controller. (Non-polarized 2-wire)

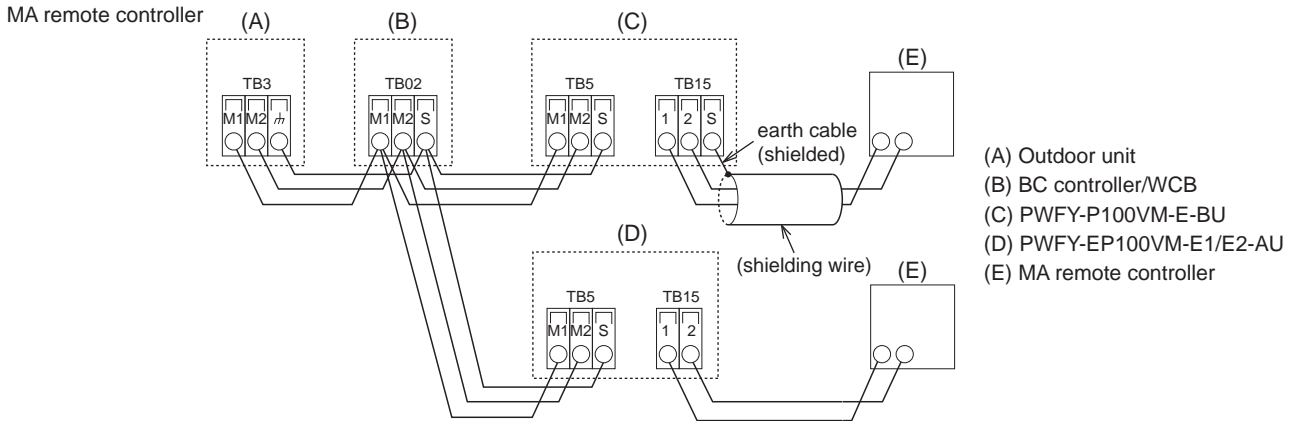

- DC 10 to 13 V between 1 and 2 (MA remote controller)

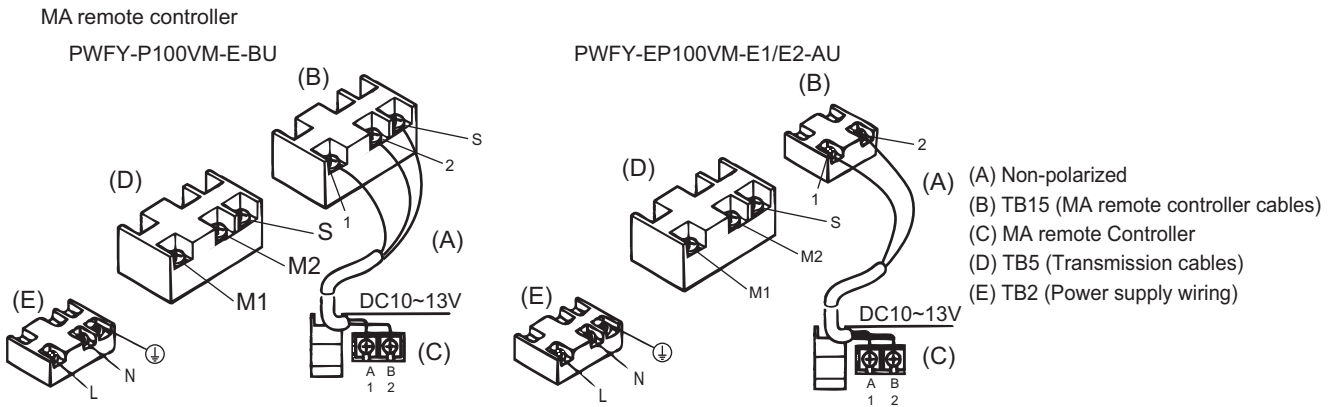

- The MA remote controller cannot be used at the same time or interchangeably.

Note

Ensure that the wiring is not pinched when fitting the terminal box cover. Pinching the wiring may cut it.

CAUTION

- Use wire with supplemental insulation.
- Input to TB142A, TB142B, and TB142C should not carry voltage.
- Cables from equipment connected to external input/output should have supplemental insulation.
- Use a single multiple-core cable for external input/output to allow for connection to the PG screw.

Wire the power supply so that no tension is imparted. Otherwise disconnection, heating or fire result.

12-5. Connecting electrical connections

Verify that the model name on the operating instructions on the cover of the control box is the same as the model name on the nameplate.

Remove the screws holding the terminal box cover in place.

•PWFY unit

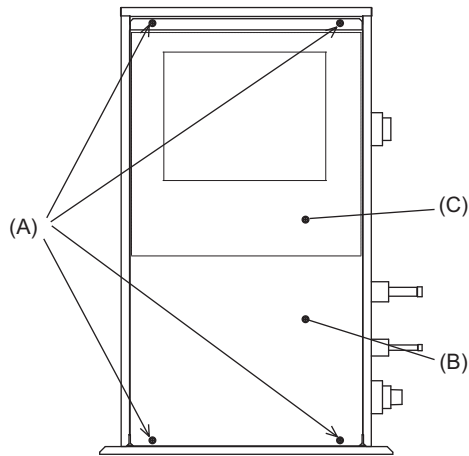

•Solenoid valve kit

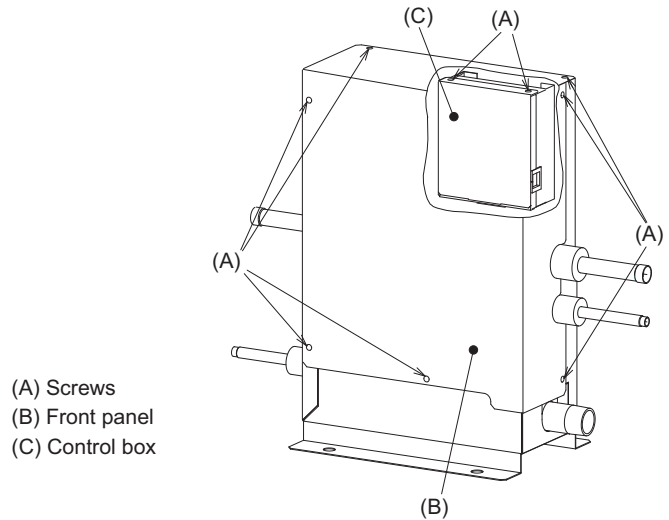

Note

Ensure that the wiring is not pinched when fitting the terminal box cover. Pinching the wiring may cut it.

⚠ CAUTION

Install wiring so that it is not tight and under tension. Wiring under tension may break, or overheat and burn.

- ♦ Fix power source external input/output line wiring to control box by using buffer bushing for tensile force to prevent electric shock. (PG connection or the like.) Connect transmission wiring to transmission terminal block through the knockout hole of control box using ordinary bushing.
- ♦ After wiring is complete, make sure again that there is no slack on the connections, and attach the cover onto the control box in the reverse order removal.

•PWFY unit

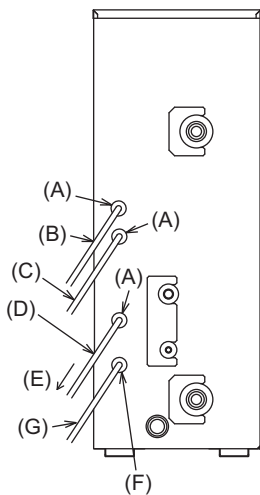

- (A) To prevent external tensile force from applying to the wiring connection section of power source terminal block use buffer bushing like PG connection or the like.
- (B) External signal input cable
- (C) External signal output cable
- (D) Power source wiring
- (E) Tensile force
- (F) Use ordinary bushing
- (G) Transmission cable and MA remote controller cable

•Solenoid valve kit

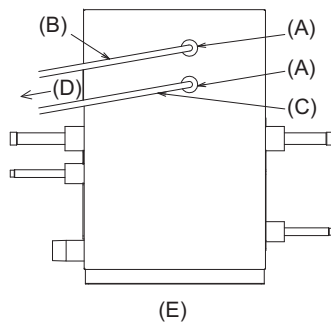

- (A) To prevent external tensile force from applying to the wiring connection section of power source terminal block use buffer bushing like PG connection or the like.
- (B) External signal input cable
- (C) Power source wiring
- (D) Tensile force
- (E) Back view

⚠ CAUTION

Wire the power supply so that no tension is imparted. Otherwise disconnection, heating or fire result.

PWFY-P-VM-E-BU,EP-VM-E1-AU, EP-VM-E2-AU

13-1. Transmission cable specifications

Transmission cables

PWFY-P100VM-E-BU

	Transmission cables	MA Remote controller cables	External input	External output
Type of cable	Shielding wire (2-core) CVVS, CPEVS or MVVS	Sheathed 2-core cable (shielded) CVVS	Sheathed multi-core cable (shielded) CVVS or MVVS	Sheathed multi-core cable (unshielded) CVV or MVV
Cable diameter	More than 1.25 mm ²	0.3 ~ 1.25 mm ²	0.3 ~ 0.5 mm ²	0.3 ~ 1.25 mm ²
Remarks	-	Max.length: 200 m	Max.length: 100 m	Rated voltage: L1-N: 220 ~ 240 V Rated load: 0.6 A

PWFY-EP100VM-E1/E2-AU

	Transmission cables	MA Remote controller cables	External input	External output
Type of cable	Shielding wire (2-core) CVVS, CPEVS or MVVS	Sheathed 2-core cable CVV (unshielded)	Sheathed multi-core cable CVV or MVV (unshielded)	Sheathed multi-core cable (unshielded) CVV or MVV
Cable diameter	More than 1.25 mm ²	0.3 ~ 1.25 mm ²	0.3 ~ 0.5 mm ²	0.3 ~ 1.25 mm ²
Remarks	-	Max.length: 200 m	Max.length: 100 m	Rated voltage: L1-N: 220 ~ 240 V Rated load: 0.6 A

CVVS, MVVS: PVC insulated PVC sheathed shielded control cable

CVV, MVV: PVC insulated PVC sheathed control cable

CPEVS: PE insulated PVC sheathed shielded communication cable

13-2. Indoor unit address setting

(Be sure to operate with the main power turned OFF.)

<Address board>

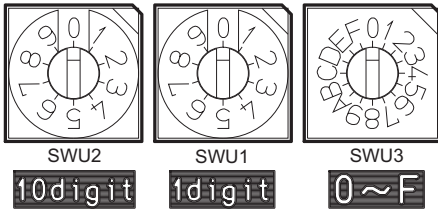

PWFY-P-VM-E-BU, EP-VM-E1-AU, EP-VM-E2-AU

13-2-1. Switch operation (BC controller)

• There are two types of rotary switch setting available: setting addresses 1 to 9 and over 10, and setting branch numbers.

a) How to set addresses

Example: If Address is "3", SWU2 (for over 10) remains at "0", and match SWU1 (for 1 to 9) to "3".

b) How to set branch numbers SWU3 (only for R2/WR2-Series)

Branch number matches the BC controller branch number. If two branches are used, SWU3 should be set to a smaller branch number. For other than R2/WR2-Series, remain SWU3 as "0".

- example -

<BC controller>

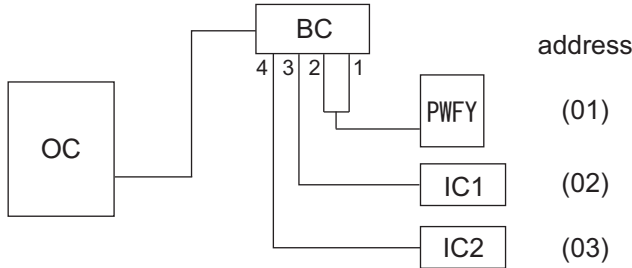

	SWU2	SWU1	SWU3
PWFY (01)	0	1	1
IC1 (02)	0	2	3
IC2 (03)	0	3	4

13-2-2. Switch operation (WCB)

a) How to set addresses

Example: If Address is "3", SWU2 (for over 10) remains at "0", and match SWU1 (for 1 to 9) to "3".

b) How to set branch numbers SWU3 (only for R2-Series)

There are two branches for WCB. Indoor unit/PWFY connecting branch should be set as "0" and PWFY connecting branch as "1".

- example -

<WCB>

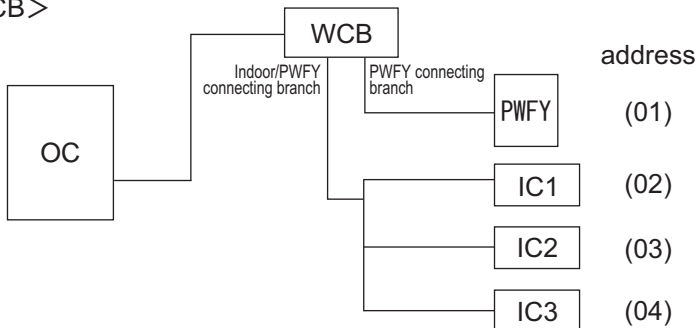

	SWU2	SWU1	SWU3
PWFY (01)	0	1	1
IC1 (02)	0	2	0
IC2 (03)	0	3	0
IC3 (04)	0	4	0

13-3. External input/output function

Preset temperature input (external analog input: 4mA-20mA)

- External input
Input through CN421, CN422 on the circuit board.

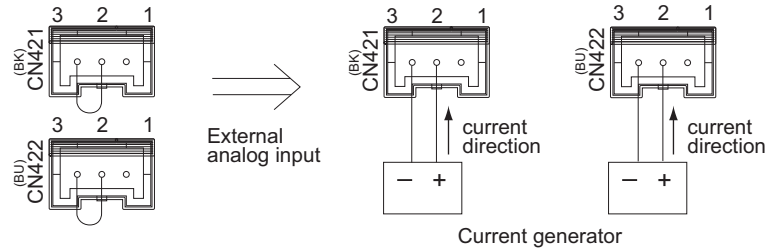

- External analog input
Use the supplied connector.
If no temperature settings are made via the MA remote controller, the temperature changes with the current of generator.

Method

Input T(A), T(B) } Changeable with PAR-W21MAA
4mA :T(A)
20mA:T(B)

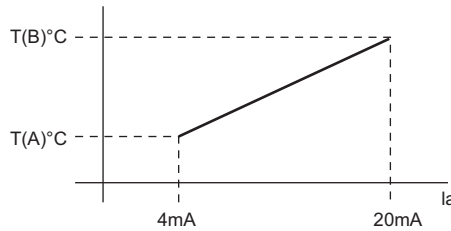

S/W default
T(A)=10°C
T(B)=70°C.

*All setting with a controller.

Conversion equation: $To = \{T(B) - T(A)\} / 16 \times I_a + [T(A) - \{T(B) - T(A)\} / 4]$
To: set temperature, Ia: analogue input value (mA)

Calculation example: T(A)=30°C, T(B)=70°C, Ia=10mA
Conversion equation: $To = 2.5 \times I_a + 20$ To=45°C

External output terminal

External output terminal (refer to [Fig. 1-7-A]) is ineffective when the circuit is open.
Refer to [Table 1] for information about each contact.

The current and voltage in the circuit to be connected to external output terminal (TB141A OUT1) must meet the following conditions.

When a solenoid valve kit is connected

- Connect the "1" and "2" on solenoid valve kit TB1 to the OUT1 on PWFY external output terminal.
- Run the external signal input cable through the access hole for external wiring output wire on the PWFY unit.
If the hole is already used to run other wires from the existing PWFY units, use any other wire access holes except the control wire access hole.

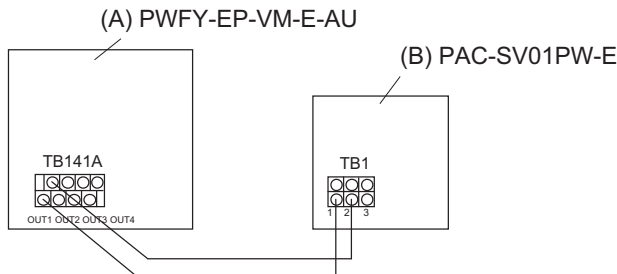

		Contact rating current
Contact rating voltage	AC250V	1A or less
	AC125V	3A or less
	DC30V	3A or less

[Table 1]

OUT1	Operation ON/OFF
OUT2	Defrost
OUT3 *7	Compressor
OUT4	Error signal

[Fig. 1-7-A]

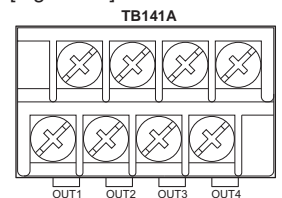

External input terminal

The piping length must be within 100 m.

External input terminal (refer to [Fig. 1-7-B]) is ineffective when the circuit is open.

Refer to [Table 2] through [Table 4] for information about each contact.

Only the "pump interlock" function is ineffective when the circuit is short-circuited.

Connect a relay circuit to the external output terminal as shown in [Fig. 3-1-F].

The specifications of the relay circuit to be connected must meet the following conditions.

Contact rating voltage \geq DC15V

Contact rating current \geq 0.1A

Minimum applicable load \leq 1mA at DC

[Table 2] TB142A

IN1	Pump interlock
-----	----------------

[Table 3] TB142B

IN3	Connection demand
IN4	Operation ON/OFF

[Table 4] TB142C

COM+	Common
IN5 *1	Hot Water/Heating
IN6 *2	Heating ECO *5
IN7 *3	Anti-freeze *6
IN8 *4	Cooling operation

*1 PWFY-P100VM-E-BU ... Hot Water

PWFY-EP100VM-E1/E2-AU ... Heating

*2 Effective when SW 4-3 is set to ON.

*3 Effective when SW 4-4 is set to ON.

*4 PWFY-EP100VM-E1/E2-AU only

*5 When Heating ECO mode is effective, the outlet water temp. will be changed based on ambient temp. automatically.
(Only Y/HP (ZUBADAN)/R2-Series)

*6 When Anti-freeze mode is effective, the unit will set the heating temperature range between 10°C~45°C enabling the unit to maintain low water temperature to prevent water pipes from freezing.

*7 PWFY-P100VM-E-BU only

Note

When setting Heating ECO or Anti-freeze mode, reset all power supply of all units (outdoor/indoor units).

Dip S/W 1-1 OFF: Water Inlet Temp.

Dip S/W 1-1 ON: Water Outlet Temp.

The factory setting for Dip SW 1-1 is OFF.

Signal priority = External input > centralized controller > remote controller

14-1. Solenoid valve kit piping design

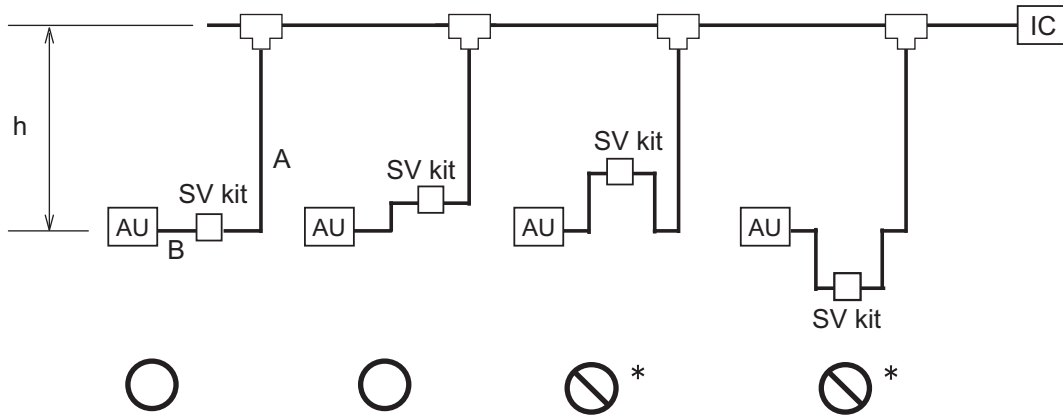

*Do not install the Solenoid valve kit on the square-arch-shaped piping as shown in the figure above.

Piping length limitation

Item	Piping in the figure	Max. length (m)
Farthest AU from first joint	A+B	40
Length between AU and SV kit	B	5
Height between AU and IC (AU)	h	15

14-2. WCB piping design

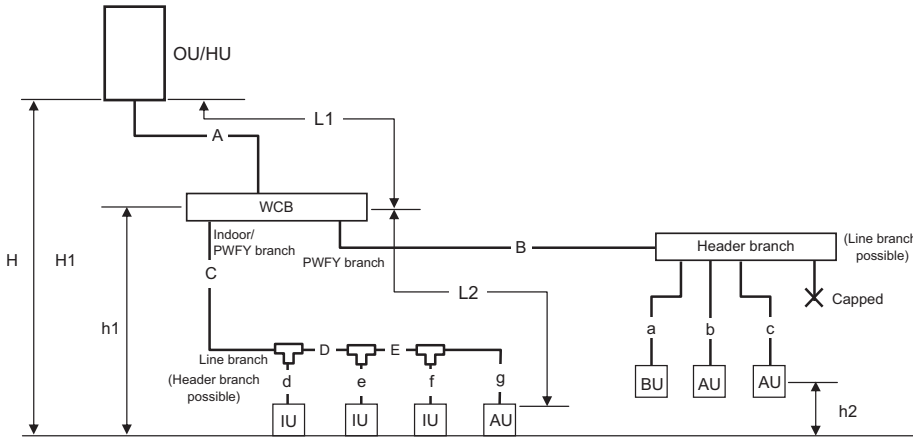

Item	Piping in the figure	Maximum length
Total piping length	$A+B+C+D+E+a+b+c+d+e+f+g$	*1
Farthest IU from OU/HU	$A+C+D+E+g/A+B+c$	165 m (Max. equivalent length of 190 m or less)
Distance between OU/HU and WCB	A	110
Distance between IU and WCB	$C+D+E+g/B+c$	40 ²
Height between IU and OU/HU	OU/HU above IU	H
	OU/HU below IU	H1
Height between IU and WCB		15 (10) ³
		15 (10) ³

- *1. Refer to Fig. (A) "Restrictions on piping length".
- *2. Please refer to Fig. (B) "Distance between WCB and farthest indoor unit" when the distance between WCB controller and farthest indoor unit exceeds 40 m. (Not applicable to the P250 model indoor unit).
- *3. The values in the parenthesis show the maximum piping length when the capacity of the connected indoor unit is 200 or more.

NOTE:

Joint branching is not possible after header branching.
 Cover the unused branch using the optional cover cap (CMY-S202-J).
 Top-bottom differential 90m(OU above IU) or 60m(OU below IU) is not available.

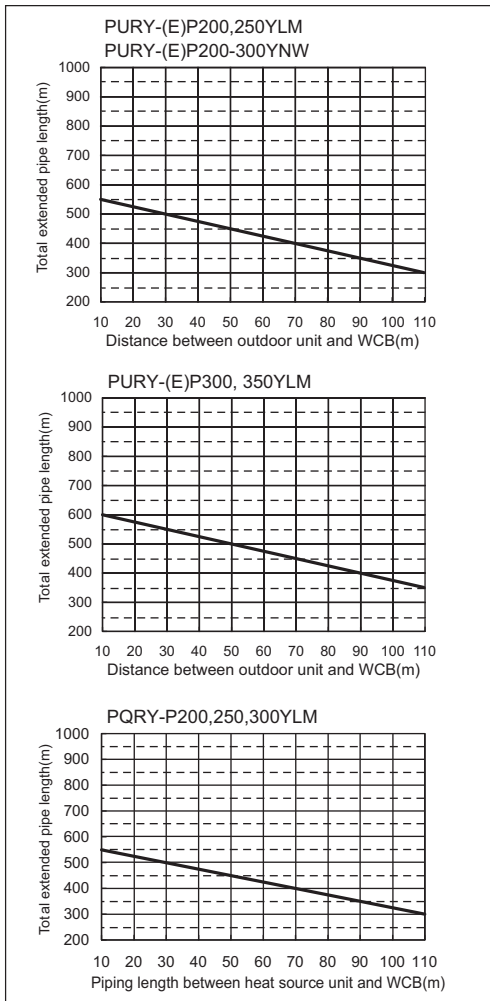

Fig. (A) Restrictions on piping length

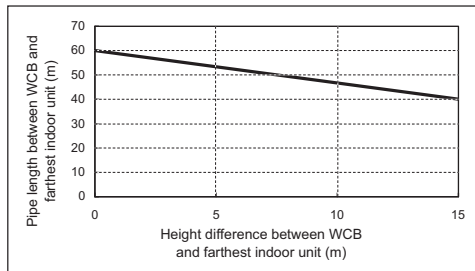

Fig. (B) Distance between WCB and farthest indoor unit

Piping "B", "C", "D", "E" size selection rule (mm)

Total capacity of indoor units	Liquid pipe	Gas pipe
-140	ø9.52	ø15.88
14-200	ø9.52	ø19.05
201-300	ø9.52	ø22.2
301-400	ø12.7	ø28.58
401-	ø15.88	ø28.58

Piping "a", "b", "c", "d", "e", "f", "g" size selection rule (mm)

Model number	Liquid pipe	Gas pipe
15, 20, 25, 32, 40, 50	ø6.35	ø12.7
63, 71, 80, 100, 125, 140	ø9.52	ø15.88
200	ø9.52	ø19.05
250	ø9.52	ø22.2

Selection rule for branch pipe (joint)

Downstream unit model total	Joint
-200	CMY-Y102SS-G2
201-400	CMY-Y102LS-G2
401-	CMY-Y202S-G2

Selection rule for branch pipe (header)

For PURY-Series		
4-Branching header (Downstream unit model total ≤ 200)	8-Branching header (Downstream unit model total ≤ 400)	10-Branching header (Downstream unit model total ≤ 650)
CMY-Y104-G	CMY-Y108-G	CMY-Y1010-G
For PQRV-Series		
4-Branching header (Downstream unit model total ≤ 200)	8-Branching header (Downstream unit model total ≤ 350)	10-Branching header (Downstream unit model total ≤ 600)
CMY-Y104-G	CMY-Y108-G	CMY-Y1010-G

14-3. Refrigerant charging calculation (PWFY-AU with R2 system)

It is needed to add extra refrigerant if the system is under the following conditions.
See the attachment for how to decide the amount of refrigerant to be added to each outdoor unit.
The graph below shows an example.

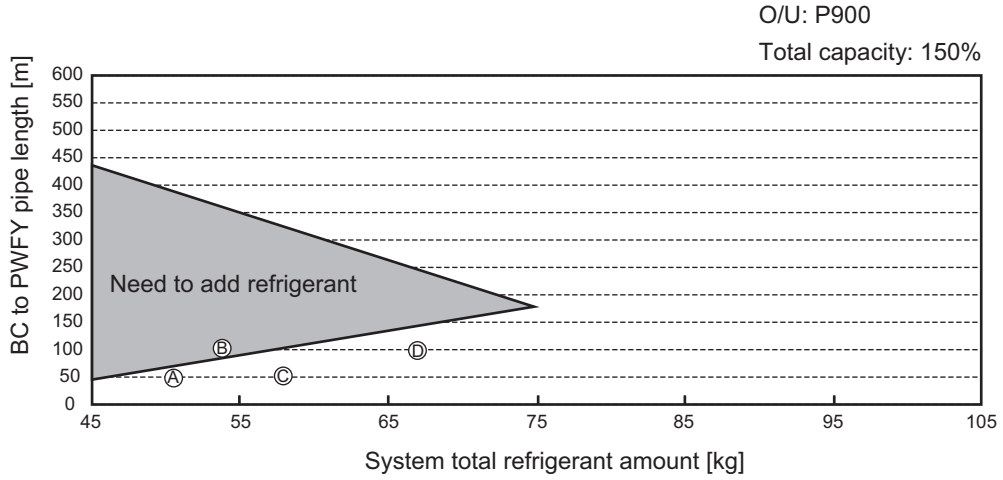

- Ⓐ Main pipe: 40m
PWFY: P200 x 4, Pipe 12.5m each
- Ⓑ Main pipe: 40m
PWFY: P200 x 4, Pipe 25m each
- Ⓒ Main pipe: 40m
PWFY: P200 x 2, Pipe 25m each
IC: P50 x 10, Pipe 20m each (100%)
- Ⓓ Main pipe: 40m(BC) + 20m(BS)
PWFY: P200 x 4, Pipe 25m each
IC: P50 x 11, Pipe 20m each (150%)

Extra charge amount (kg): BC to PWFY pipe length (m) × 0.1

PURY-P200, PURY-EP200

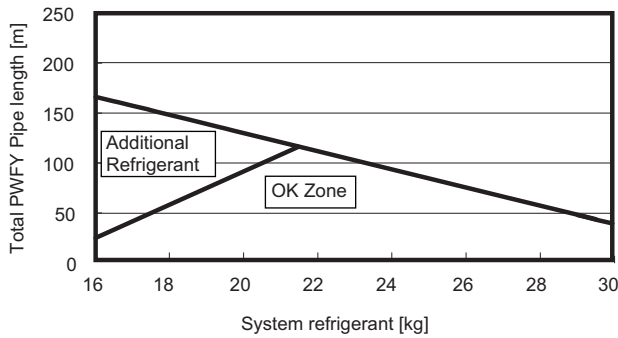

PURY-P250, PURY-EP250

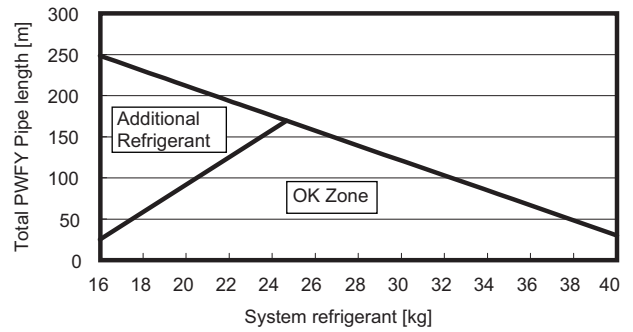

PURY-P300, PURY-EP300

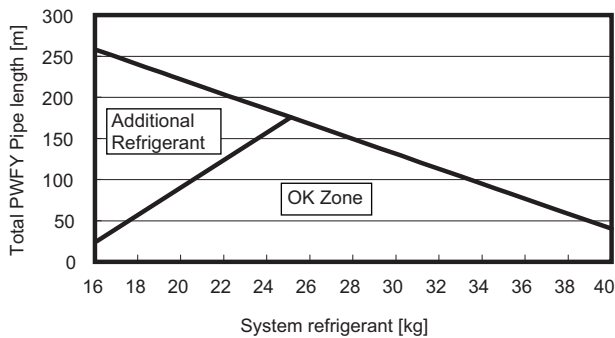

PURY-P350, PURY-EP350

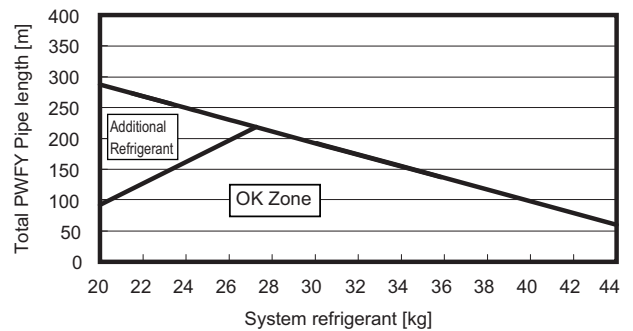

PWFY-P-VM-E-BU,EP-VM-E1-AU, EP-VM-E2-AU

PURY-P400, PURY-EP400

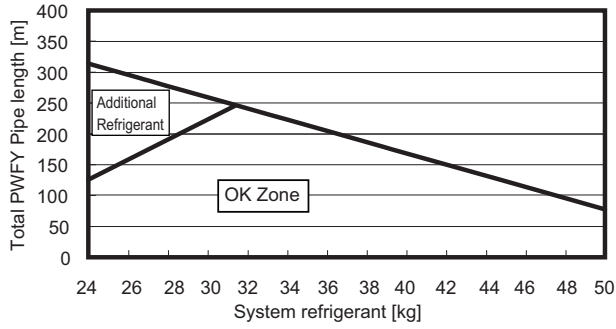

PURY-P450, PURY-EP450

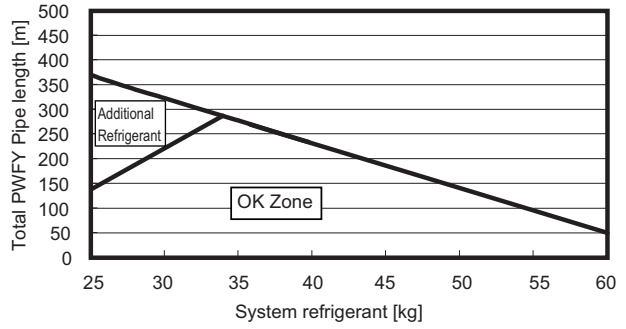

PURY-P500, PURY-EP500

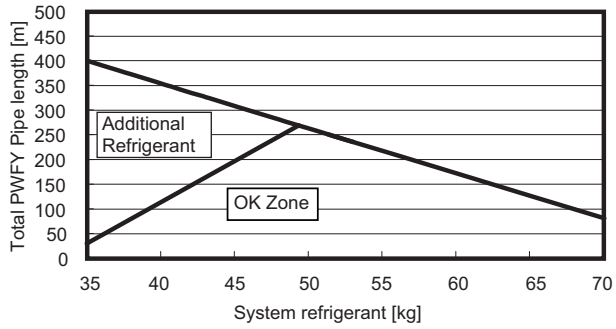

PURY-P550, PURY-EP550

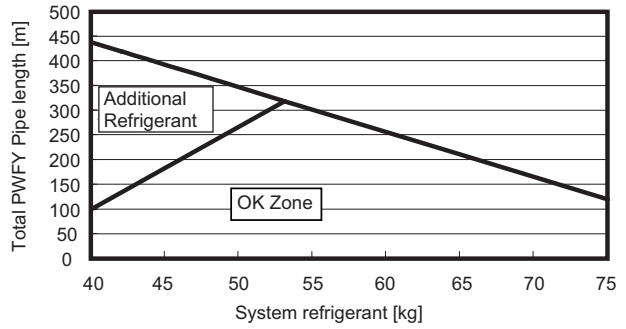

PURY-P600, PURY-EP600

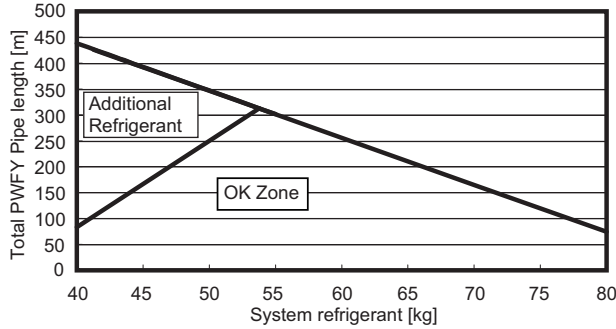

PURY-P650, PURY-EP650

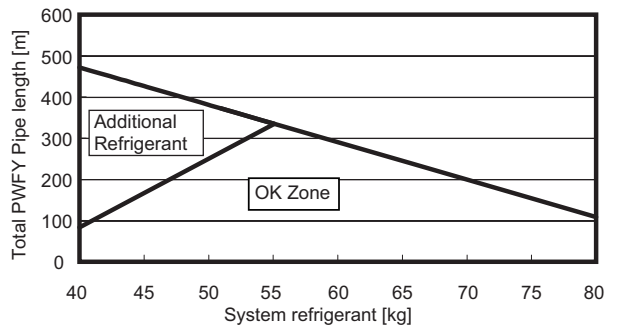

PURY-P700, PURY-EP700

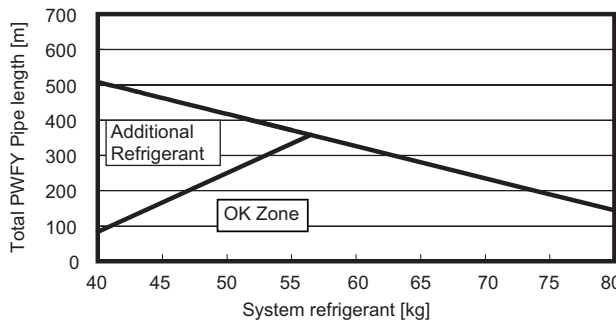

PURY-P750,800,850,900, PURY-EP700

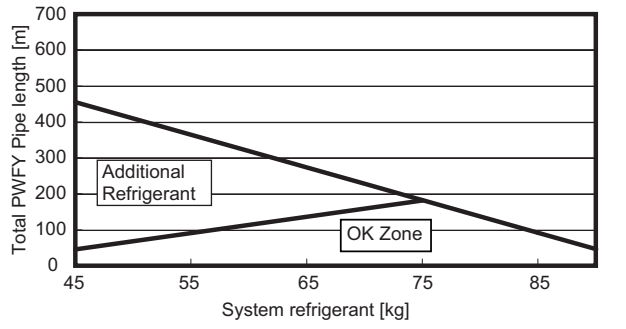

*Total PWFY pipe length
Shows the total length of gas pipes from PWFY units that are connected to the system

15-1. How to calculate the necessary heating capacity

Heating capacity calculation

A. For Air conditioning using such as Panel Heaters, Floor Heating and Fan coil units
 Required total heating capacity kW
 Safety factor; %

B. For Sanitary use such as Shower and Bathrooms
 Conditions
 Tank inlet water Temp.; °C
 Tank outlet water Temp.; °C
 (Set Temp -5 °C)
 Safety factor for Heat Loss; %
 Operating time; Hours
 For Shower; ℓ/person x Person = ℓ (Water Temp. Condition °C)
 For Bathrooms; ℓ/Person x Person = ℓ (Water Temp. Condition °C)

The conversion of water volume to °C
 x (-) / (-)
 + x (-) / (-)
 = ℓ/day

Heating Capacity Calculation for sanitary usage
 / 1,000 x (-) = M cal / day

The conversion of M cal to kW
 / 860 x 1,000 / = kW

C. Total (A+B)
 Total Heating Capacity
 x (100% + %) + x (100% + %) = kW

D. No. of units required
 Safety factor; %
 x (100% + %) / 12.5 kW* = units
 ↓
 units are required

Calculation example

A. For Air conditioning using such as Panel Heaters, Floor Heating and Fan coil units
 Required total heating capacity kW
 Safety factor; %

B. For Sanitary use such as Shower and Bathrooms
 Conditions
 Tank inlet water Temp.; °C
 Tank outlet water Temp.; °C
 (Set Temp -5 °C)
 Safety factor for Heat Loss; %
 Operating time; Hours
 For Shower; ℓ/person x Person = ℓ (Water Temp. Condition °C)
 For Bathrooms; ℓ/Person x Person = ℓ (Water Temp. Condition °C)

The conversion of water volume to °C
 x (-) / (-)
 + x (-) / (-)
 = ℓ/day

Heating Capacity Calculation for sanitary usage
 / 1,000 x (-) = M cal / day

The conversion of M cal to kW
 / 860 x 1,000 / = kW

C. Total (A+B)
 Total Heating Capacity
 x (100% + %) + x (100% + %) = kW

D. No. of units required
 Safety factor; %
 x (100% + %) / 12.5 kW* = units
 ↓
 units are required

* The value shown here is the rated capacity, and varies depending on the installation conditions.

15-2. Selecting an installation site

- Do not install outdoors. The unit is not waterproof.
- Back up system is recommended in case of PWFY unit breakdown.
- The unit will get hot. Do not install in a location where heat gets trapped inside.
- Be sure to install unit in a place strong enough to withstand its weight.
Any lack of strength may cause unit to fall down, resulting in a personal injury.
- Do not install the unit where corrosive gas is generated.
- Have installation work in order to protect against earthquake.
Any installation deficiency may cause unit to fall down, resulting in a personal injury.
- Pay a special attention to the place, such as a basement, etc. where refrigeration gas can stay, since refrigeration is heavier than the air.
- Do not install the unit where combustible gas may leak.
 - If the gas leaks and accumulates around the unit, an explosion may result.
- When installing the unit in a hospital, communication station, or similar place, provide sufficient protection against noise.
 - The inverter equipment, private power generator, high-frequency medical equipment, or radio communication equipment may cause the air conditioner to operate erroneously, or fail to operate. On the other hand, the air conditioner may affect such equipment by creating noise that disturbs medical treatment or image broadcasting.
- Do not install the unit on a structure that may cause leakage.
 - When the room humidity exceeds 80% or when the drain pipe is clogged, condensation may drip from the indoor unit. Perform collective drainage work together with the unit, as required.
- It is recommended that a water pump is connected to each PWFY unit.

15-3. Securing installation and service space

- Please secure the following service spaces after installation.
(All servicing can be performed from the front of the unit)

▪ PWFY unit

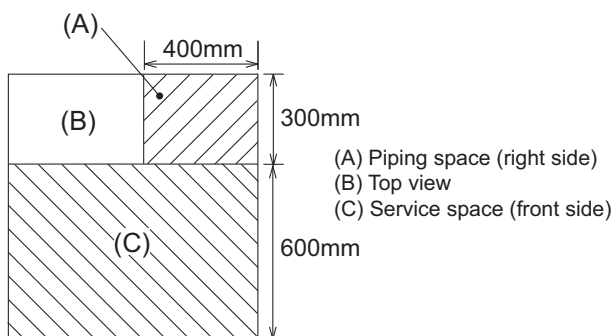

▪ Solenoid valve kit

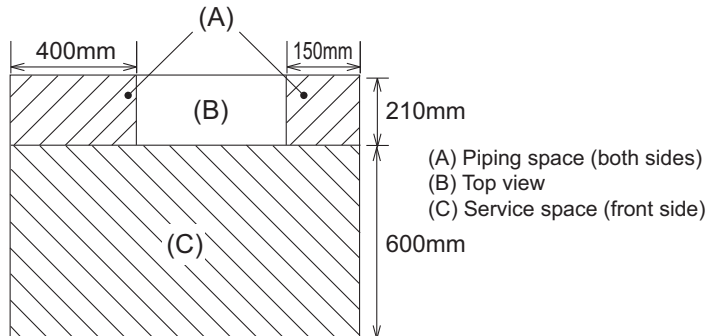

⚠ WARNING

- Be sure to install the unit in a location which can adequately support its weight.
 - If there is insufficient strength to support the unit's weight, it could fall and cause injuries.

15-4. Installing the unit

15-4-1. Lifting method

⚠ CAUTION

Be very careful when carrying the product.

- Do not have only one person to carry product if it is more than 20 kg.
- Do not tilt the unit while transporting.
- PP bands are used to pack some products. Do not use them as a mean for transportation because they are dangerous.
- Tear plastic packaging bag and scrap it so that children cannot play with it. Otherwise plastic packaging bag may suffocate children to death.

Product net weight

Model	PWFY-P100VM-E-BU	
Net weight	59 kg	
Model	PWFY-EP100VM-E1-AU	PWFY-EP100VM-E2-AU
Net weight	33 kg	36 kg

15-4-2. Installation method

• Using the anchoring holes shown below, firmly bolt the unit to the base.

▪ PWFY unit

▪ Solenoid valve kit

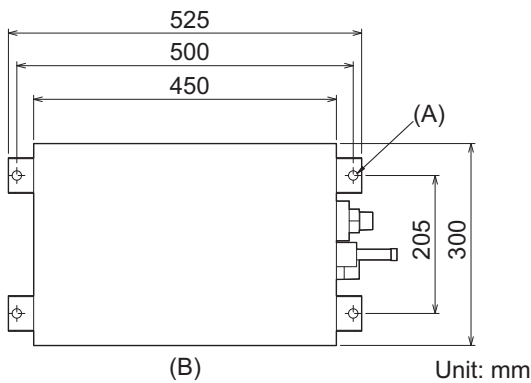

(A) 4- ϕ 14 (Anchoring hole)
(B) (Top view)

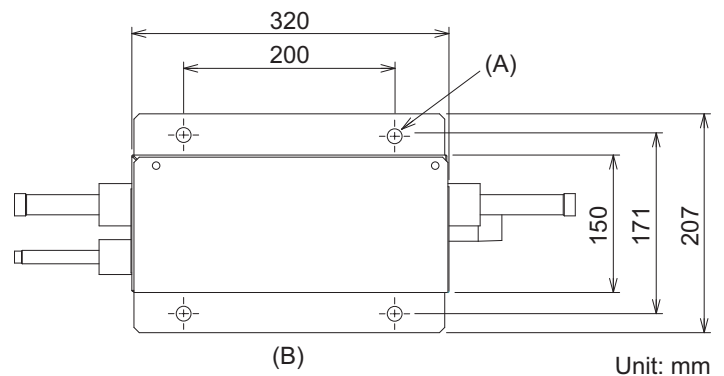

(A) 4- ϕ 14 (Anchoring hole)
(B) (Top view)

Bases

- ♦ Be sure to install unit in a place strong enough to withstand its weight. If the base is unstable, reinforce with a concrete base.
- ♦ The unit must be anchored on a level surface. Use a level to check after installation.
- ♦ If the unit is installed near a room where noise is a problem, using an anti-vibration stand on the base of the unit is recommended.

15-5. Refrigerant pipe and drain pipe specifications

15-5-1. Refrigerant pipe and drain pipe specifications

To avoid dew drops, provide sufficient anti-sweating and insulating work to the refrigerant and drain pipes. When using commercially available refrigerant pipes, be sure to wind commercially available insulating material (with a heat-resisting temperature of more than 100 °C and thickness given below) onto both liquid and gas pipes. Be also sure to wind commercially available insulating material (with a form polyethylene's specific gravity of 0.03 and thickness given below) onto all pipes which pass through rooms.

1) Select the thickness of insulating material by pipe size.

Unit: mm

Model	PWFY-P100VM-E-BU	PWFY-EP100VM-E1-AU PWFY-EP100VM-E2-AU	PAC-SV01PW-E
Gas	ø15.88	ø15.88	Depends on the pipe diameter of the PWFY unit to be connected.
Liquid	ø9.52	ø9.52	
Drain	ø32		
Insulating material's thickness	More than 10 mm		

2) If the unit is used on the highest story of a building and under conditions of high temperature and humidity, it is necessary to use pipe size and insulating material's thickness more than those given in the table above.

3) If there are customer's specifications, simply follow them.

15-5-2. Refrigerant pipe, drain pipe and filling port

- PWFY unit
- Solenoid valve kit

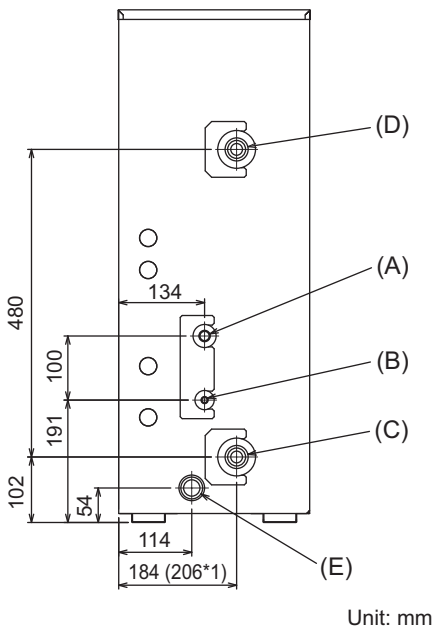

- (A) Refrigerant piping (gas)
- (B) Refrigerant piping (liquid)
- (C) Water inlet
- (D) Water outlet
- (E) Drain outlet
- *1: PWFY-P100VM-E1, E2-AU

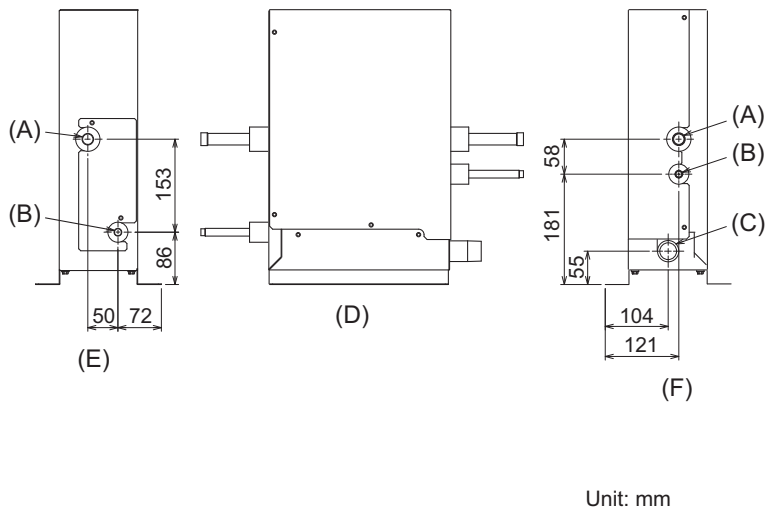

- (A) Refrigerant piping (gas)
- (B) Refrigerant piping (liquid)
- (C) Drain outlet
- (D) Front view
- (E) Left side view
- (F) Right side view

15-6. Connecting refrigerant pipes and drain pipes

15-6-1. Refrigerant piping work

This piping work must be done in accordance with the installation manuals for both outdoor unit and BC controller/WCB (simultaneous cooling and heating R2-Series).

- R2-Series is designed to operate in a system that the refrigerant pipe from an outdoor unit is received by BC controller/WCB and branches at the BC controller/WCB to connect between indoor units.
- The PWFY unit should be connected to 2 ports on the BC controller. (Set BC controller DIP SW 4-6 to ON)
- For constraints on pipe length and allowable difference of elevation, refer to the outdoor unit installation manual.
- The method of pipe connection is brazing connection.

⚠ CAUTION

- Install the refrigerant piping for the indoor unit in accordance with the following.
- 1) Cut the tip of the indoor unit piping, remove the gas, and then remove the brazed cap.

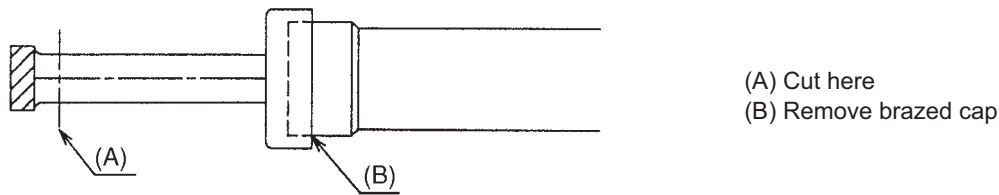

- 2) Pull out the thermal insulation on the site refrigerant piping, braze the unit piping, and replace the insulation in its original position. Wrap the piping with insulating tape.

Note

- Pay strict attention when wrapping the copper piping since wrapping the piping may cause condensation instead of preventing it.
- Before brazing the refrigerant piping, always wrap the piping on the main body, and the thermal insulation piping, with damp cloths to prevent heat shrinkage and burning the thermal insulation tubing. Take care to ensure that the flame does not come into contact with the main body itself.

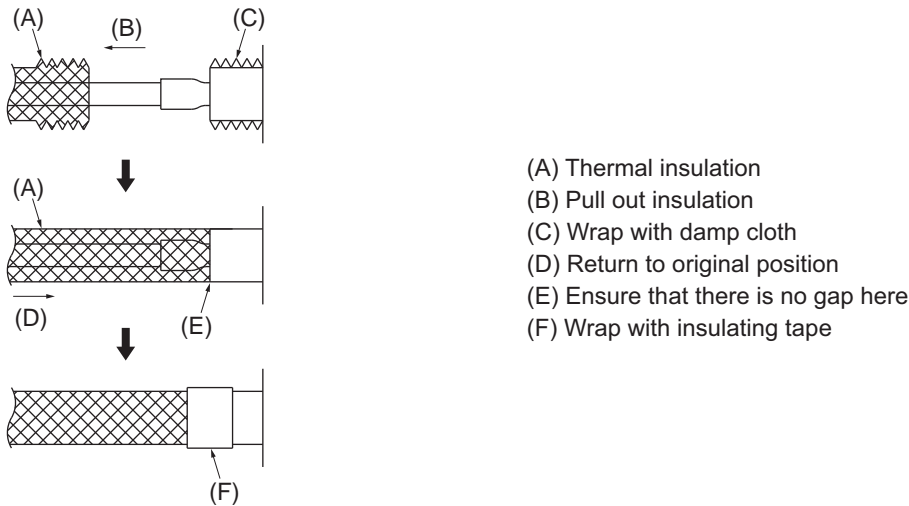

15-6-2. Mixed system of PWFY-AU and Indoor unit (Y, HP (ZUBADAN), WY system)

Take one of the countermeasures listed below.

- 1) Install the External Solenoid Valve (except on PWFY-EP100VM-E2-AU)
- 2) Add brine, assuming that the temperature will drop to -20°C.
Set Dip SW 1-10 (on ATW unit) to ON if brine is added.

*Refer to P62 "Brine" in section 15-7. Water pipe installation.

* With the WY system, the above steps apply only when operating the WY at the water temperature below 10°C.

15-6-3. PWFY-AU in cooling operation (Y, HP (ZUBADAN), WY system)

Add brine, assuming that the temperature will drop to -20°C.

Set Dip SW 1-10 (on ATW unit) to ON if brine is added.

* With the WY system, the above steps apply only when operating the WY at the water temperature below 10°C.

Cautions On Refrigerant Piping

- Be sure to use non-oxidative brazing for brazing to ensure that no foreign matter or moisture enter into the pipe.
- Be sure to apply refrigerating machine oil over the flare connection seating surface and tighten the connection using a double spanner.
- Provide a metal brace to support the refrigerant pipe so that no load is imparted to the indoor unit end pipe. This metal brace should be provided 500 mm away from the indoor unit's flare connection.

⚠ WARNING

When installing and moving the unit, do not charge it with refrigerant other than the refrigerant (R407C or R22) specified on the unit.

- Mixing of a different refrigerant, air, etc. may cause the refrigerant cycle to malfunction and result in severe damage.

⚠ CAUTION

- Use refrigerant piping made of C1220 (CU-DHP) phosphorus deoxidized copper as specified in the JIS H3300 "Copper and copper alloy seamless pipes and tubes". In addition, be sure that the inner and outer surfaces of the pipes are clean and free of hazardous sulphur, oxides, dust/dirt, shaving particles, oils, moisture, or any other contaminant.
- Never use existing refrigerant piping.
 - The large amount of chlorine in conventional refrigerant and refrigerator oil in the existing piping will cause the new refrigerant to deteriorate.
- Store the piping to be used during installation indoors and keep both ends of the piping sealed until just before brazing.
 - If dust, dirt, or water gets into the refrigerant cycle, the oil will deteriorate and the compressor may fail.

15-6-4. Drain piping work

- 1) Ensure that the drain piping is downward (pitch of more than 1/100) to the outdoor (discharge) side. Do not provide any trap or irregularity on the way. (a)
- 2) Ensure that any cross-wise drain piping is less than 20 m (excluding the difference of elevation). If the drain piping is long, provide metal braces to prevent it from waving. Never provide any air vent pipe. Otherwise drain may be ejected.
- 3) Use a hard vinyl chloride pipe VP-25 (with an external diameter of 32 mm) for drain piping.
- 4) Ensure that collected pipes are 100 mm lower than the unit body's drain port as shown in (b).
- 5) Do not provide any odor trap at the drain discharge port.
- 6) Put the end of the drain piping in a position where no odor is generated.
- 7) Do not put the end of the drain piping in any drain where ionic gases are generated.

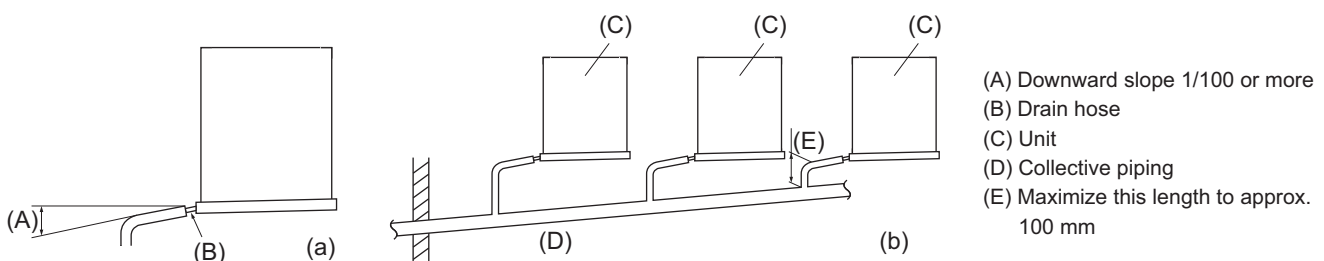

15-7. Water pipe installation

Water circuit sample

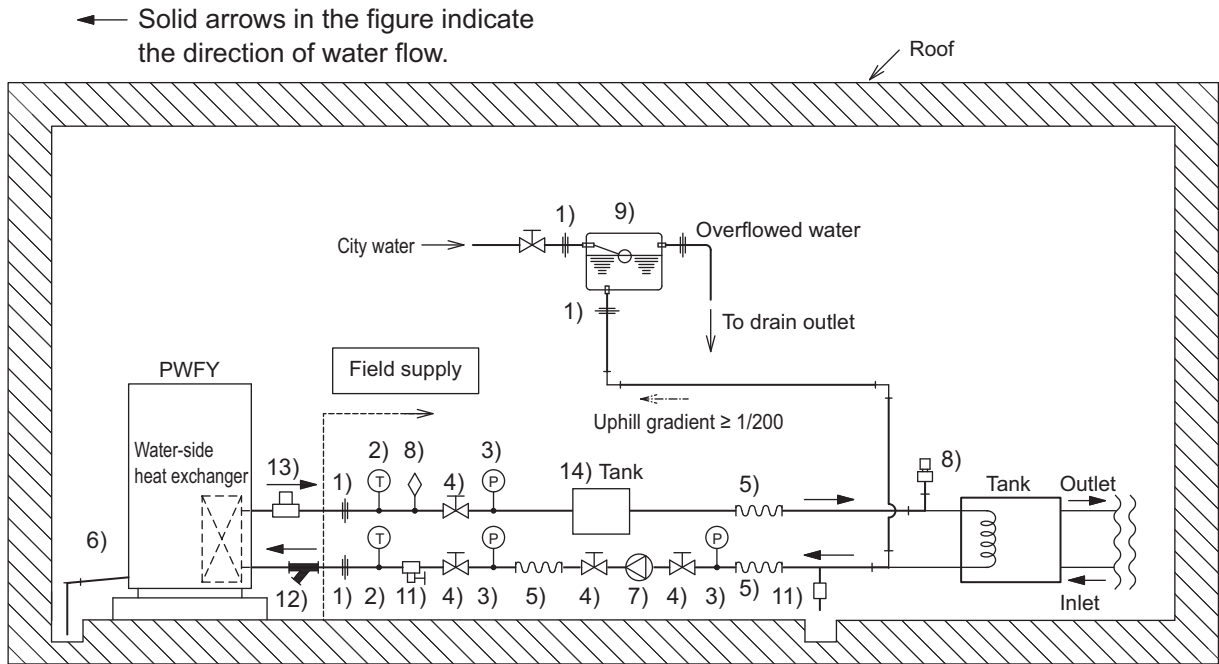

Sample of water circuit for PWFY

Consider the following when designing and installing a water piping system.
(Items (1)-(14) in the figure are explained below.)

- 1) Union joints/flange joints etc.
Install a flange etc. to allow for easy replacement of connected equipment.
- 2) Thermometer
For checking unit performance and operation monitoring
- 3) Water pressure gauge
For operation status monitoring
- 4) Valve
Install a valve for easy replacement and cleaning of the refrigerant flow control device.
Install a refrigerant flow control valve on the fan coil outlet side.
- 5) Flexible joint
Recommended to prevent the noise and vibration from the pump from being transmitted.
- 6) Drain pipe
Install the drain pipe with an inclination of between 1/100 and 1/200 to provide a downward flow of drain water.
For cold climate installation, take an appropriate measure (e.g., drain heater) to prevent the drain water from freezing.
- 7) Pump
Use a pump that is large enough to compensate for the total water pressure loss and to supply sufficient water to the unit.
- 8) Air vent valve
Provide air vent valves on the pipes.
- 9) Expansion tank
Install an expansion tank to accommodate expanded water and to supply water.
- 10) Cold/Hot water pipe
Use pipes that allow for easy air purging, and provide sufficient insulation.
- 11) Drain valve
Install drain valves so that water can be drained for servicing.
- 12) Strainer
Install a strainer near the PWFY unit to keep foreign materials from entering the water-side heat exchanger.
- 13) Flow switch
Install the supplied flow switch on the outlet pipe.
- 14) Tank
Minimum tank capacity: 100 L (Refer to [Fig. 3-1-D])

Caution for water pipe installation

Consider the following when designing and installing a water piping system.

- Do not use steel pipes as water pipes.
 - Copper pipes or stainless steel pipes are recommended. If iron pipes are used in the existing system, do not connect a new circuit to the old one. Keep the existing and new circuits separate.
- Light pipes are similar to other air-conditioning pipes, however, please observe the following precautions during installation.
- Before a long period of non use, purge the water out of the pipes and thoroughly let them dry.
- Use a closed water circuit.
- When operating the unit, add brine to the circulating water to prevent it from freezing. To use brine in the system, DipSW 1-10 must be set to ON.
- When installed in a low-ambient temperature environment, keep the water circulating at all times. If that is not possible, purge the water out of the pipes completely.
- Do not use the water used for this unit for drinking or food manufacturing.
- When the ambient temperature is 0 °C or lower during stop operation, keep the water circulating at all times, or purge the water out of the pipes completely.

Model	Water inlet	Water outlet
PWFY-P100VM-E-BU	R 3/4 Screw	Rc 3/4 Screw
PWFY-EP100VM-E1-AU PWFY-EP100VM-E2-AU	R 1 Screw *1	Rc 1 Screw *1

*1 When the attached expansion joints are installed.

Selecting a water pump

Use a pump that is large enough to compensate for the total water pressure loss and to supply sufficient water to the unit.

Installing the strainer

- Install the strainer at the angle of 45° or less as shown in [Fig. 3-1-A].
- Install the supplied strainer at the water inlet.

[Fig. 3-1-A]

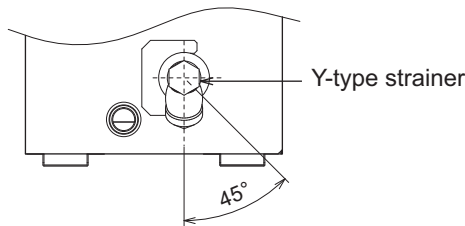

Precautions during installation

- Use the reverse-return method to insure proper pipe resistance to each unit.
- To insure easy maintenance, inspection, and replacement of the unit, use a proper joint, valve, etc. on the water intake and outlet port. In addition, be sure to install a strainer on the water intake pipe. (In order to maintain the heat source unit, a strainer on the circulating water inlet is necessary.)
 - * An example of the heat source unit installation is shown in [Fig. 3-1-B].
- Install a suitable air vent on the water pipe. After sending water through the pipe, be sure to vent the excess air.
- Condensed water may form in the low-temperature sections of heat source unit. Use a drainage pipe connected to the drain valve at the base of the unit to drain the water.
- Install a back flow-prevention valve on the pump and a flexible joint to prevent excess vibration.
- Use a sleeve to protect the pipes where they go through a wall.
- Use metal fittings to secure the pipes, and install them so that they have maximum protection against breakage and bending.
- Do not confuse the water intake and outlet valves.
- This unit doesn't have any heater to prevent freezing within tubes. When the water flow is stopped on low ambient, take out the water from tubes.
- The unused knockout holes should be closed and the opening of refrigerant pipes, water pipes, power source and transmission wires should be filled with putty and so on to prevent from moisture or the invasion of insects. (field construction)
- Wrap some sealing tape around the screw part to prevent water leakage.
- Wrap the sealing tape as follows.
 - 1) Wrap the joint with sealing tape in the direction of the threads (clockwise), and do not let the tape run over the edge.
 - 2) Overlap the sealing tape by two-thirds to three-fourths of its width on each turn. Press the tape with your fingers so that it is pressed firmly against each thread.
 - 3) Leave the 1.5th through 2nd farthest threads away from the pipe and unwrapped.
- Hold the pipe on the unit side in place with a spanner when installing the pipes or strainer. Tighten screws to a torque of 50 N.m.
- Water pipes can get very hot, depending on the preset temperature. Wrap the water pipes with insulating materials to prevent burns.
- Install the expansion joint (accessory) at the inlet after installing the strainer, and outlet.

Example of unit installation

[Fig. 3-1-B]

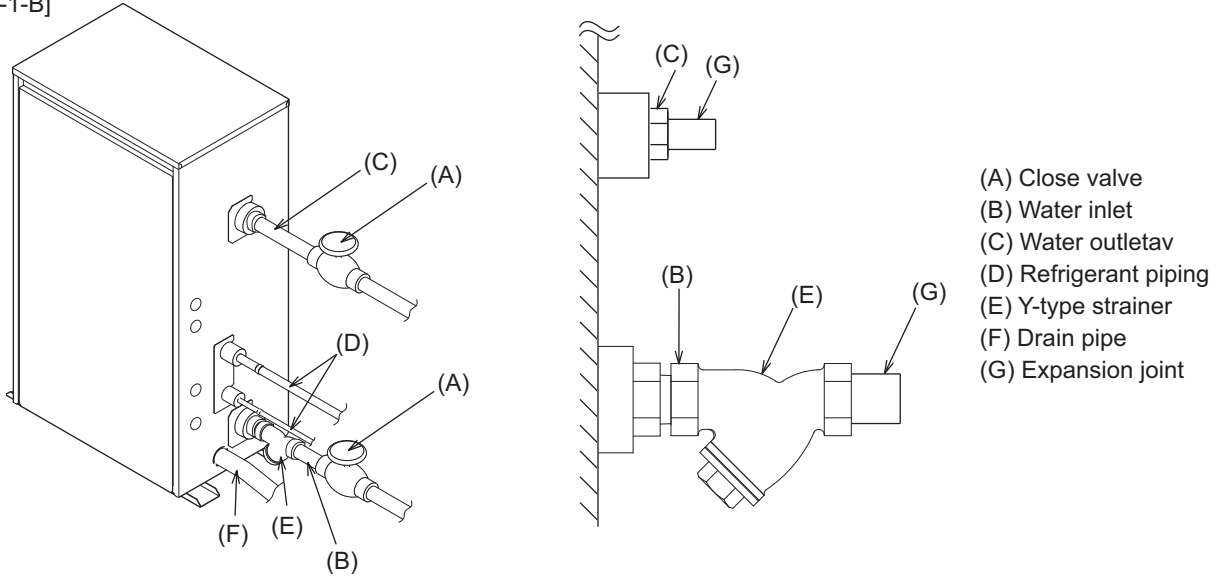

Insulation installation

The surface temperature of the water pipe would be very high, depending on the set temperature. Insulate the pipe to prevent burns.

When operating PWFY-EP100VM-E1/E2-AU with cold water, insulate the water pipe to prevent condensation. Wrap insulation material around water pipes as shown in [Fig. 3-1-C].

- Any heat source piping.
- Indoor piping in cold-weather regions where frozen pipes are a problem.
- When air coming from the outside causes condensation to form on piping.
- Any drainage piping.

[Fig. 3-1-C]

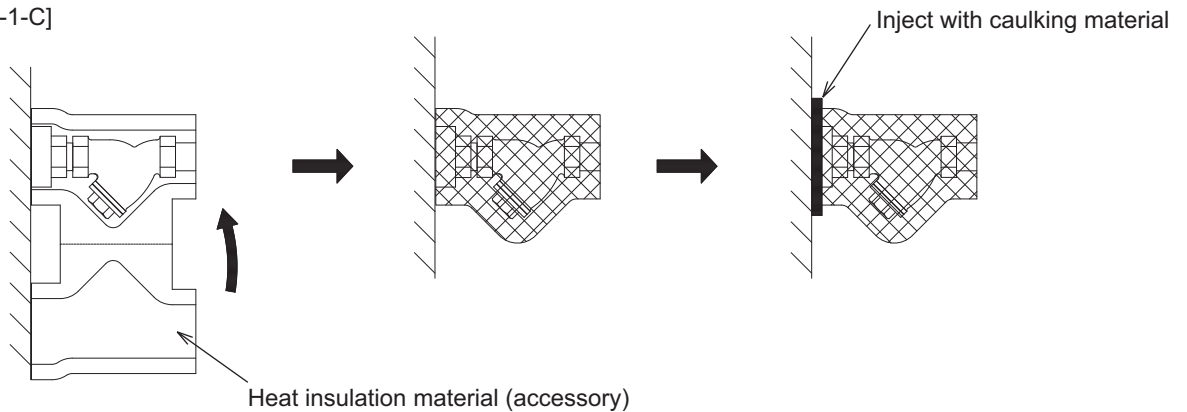

Flow switch installation

CAUTION

When installing the unit, be sure to install the supplied flow switch on the water outlet side of the unit and connect the wire to IN1 of TB142A on the unit. If the flow switch is not installed, the unit will emit the error signal (2100: Interlock error) and not operate.* A short-circuit wire is supplied, but it is only for test run.

Installation procedures

- 1) Remove the pipes attached to the flow switch.
 Note: The unit is shipped with the pipes loosely tightened.
- 2) Wrap seal tape around the threads at the end of the pipes, starting at the 1.5th or 2nd thread, and not over the openings.
 Apply two to three wraps in the direction of the pipe threads (clockwise). Each course of the tape should overlap the one before it by 2/3 to 3/4 the width of the tape. Run your fingers around the threads and tape to press the tape into the threads.
 Then, attach the pipes to the flow switch, holding parts A and B with a spanner. The maximum tightening torque is 60 N•m (611 kgf•cm).
- 3) Attach the flow switch and pipes to the water outlet in the horizontal position.
 The angle of the axis of the pipe should be less than 45 degrees.
 Check the direction of the flow switch as shown in Fig. C.
- 4) Connect the flow switch wire to IN1 of TB142A.
 From the External Wiring Input, route the wire as shown in Fig. D and connect it to the terminal as shown in Fig. E.
 Use a wire protector such as a rubber bushing in the access hole on the unit.

PWFY-P-VM-E-BU,EP-VM-E1-AU, EP-VM-E2-AU

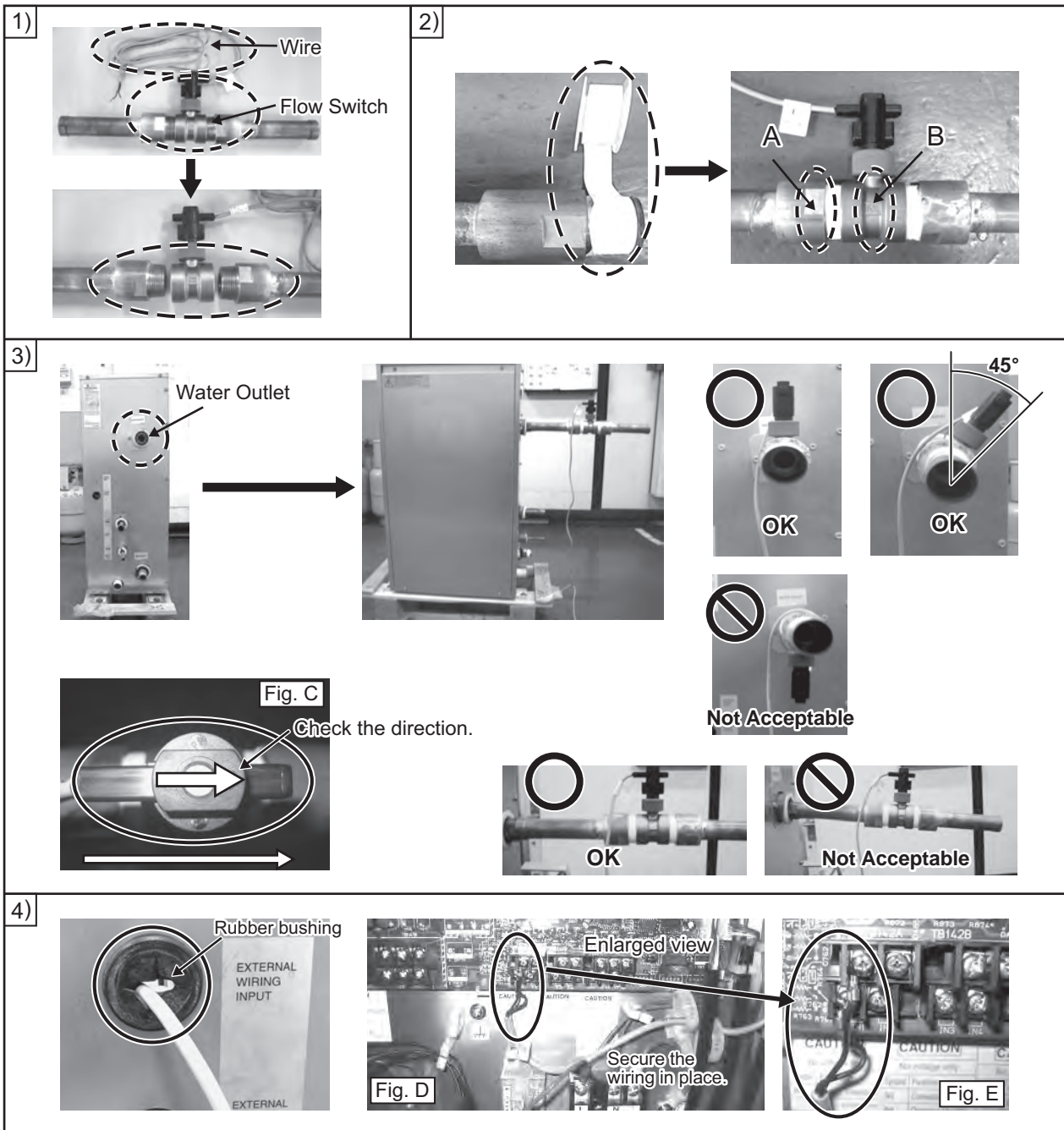

Water processing and water quality control

To preserve water quality, use the closed type of cooling tower for unit. When the circulating water quality is poor, the water heat exchanger can develop scales, leading to a reduction in heat-exchange power and possible corrosion of the heat exchanger.

Please pay careful attention to water processing and water quality control when installing the water circulation system.

♦Removal of foreign objects or impurities within the pipes.

During installation, be careful that foreign objects, such as welding fragments, sealant particles, or rust, do not enter the pipes.

♦Water Quality Processing

a) Depending on the quality of the cold-temperature water used in the air-conditioner, the copper piping of the heat exchanger may become corroded. We recommend regular water quality processing.

Cold water circulation systems using open heat storage tanks are particularly prone to corrosion.

When using an open-type heat storage tank, install a water-to-water heat exchanger, and use a closed-loop circuit on the air conditioner side. If a water supply tank is installed, keep contact with air to a minimum, and keep the level of dissolved oxygen in the water no higher than 1mg/liter.

b) Water quality standard

Items	Lower mid-range temperature water system Water Temp. <= 60 °C		Higher mid-range temperature water system Water Temp. > 60 °C		Tendency		
	Recirculating water	Make-up water	Recirculating water	Make-up water	Corrosive	Scale-forming	
Standard items	pH (25 °C)	7.0 ~ 8.0	7.0 ~ 8.0	7.0 ~ 8.0	7.0 ~ 8.0	○	○
	Electric conductivity(mS/m) (25 °C) (μ s/cm) (25 °C)	30 or less [300 or less]	30 or less [300 or less]	30 or less [300 or less]	30 or less [300 or less]	○	○
	Chloride ion (mg Cl/liter)	50 or less	50 or less	30 or less	30 or less	○	
	Sulfate ion (mg SO ₄ ²⁻ /liter)	50 or less	50 or less	30 or less	30 or less	○	
	Acid consumption (pH4.8) (mg CaCO ₃ /liter)	50 or less	50 or less	50 or less	50 or less		○
	Total hardness (mg CaCO ₃ /liter)	70 or less	70 or less	70 or less	70 or less		○
	Calcium hardness (mg CaCO ₃ /liter)	50 or less	50 or less	50 or less	50 or less		○
Reference items	Ionic silica (mg SiO ₂ /liter)	30 or less	30 or less	30 or less	30 or less		○
	Iron (mg Fe/liter)	1.0 or less	0.3 or less	1.0 or less	0.3 or less	○	○
	Copper (mg Cu/liter)	1.0 or less	1.0 or less	1.0 or less	1.0 or less	○	
	Sulfide ion (mg S ²⁻ /liter)	not to be detected	not to be detected	not to be detected	not to be detected	○	
	Ammonium ion (mg NH ₄ ⁺ /liter)	0.3 or less	0.1 or less	0.1 or less	0.1 or less	○	
	Residual chlorine (mg Cl/liter)	0.25 or less	0.3 or less	0.1 or less	0.3 or less	○	
	Free carbon dioxide (mg CO ₂ /liter)	0.4 or less	4.0 or less	0.4 or less	4.0 or less	○	
Ryzner stability index	-	-	-	-	○	○	

Reference: Guideline of Water Quality for Refrigeration and Air Conditioning Equipment. (JRA GL02E-1994)

c) Please consult with a water quality control specialist about water quality control methods and water quality calculations before using anti-corrosive solutions for water quality management.

d) When replacing a previously installed air conditioning device (even when only the heat exchanger is being replaced), first conduct a water quality analysis and check for possible corrosion.

Corrosion can occur in cold-water systems even if there has been no prior signs of corrosion.

If the water quality level has dropped, please adjust water quality sufficiently before replacing the unit. Refer to the below graph for the maximum amount of circulating water in the water pipe. Make sure that this amount does not exceed.

[Fig. 3-1-D] Maximum circulating water

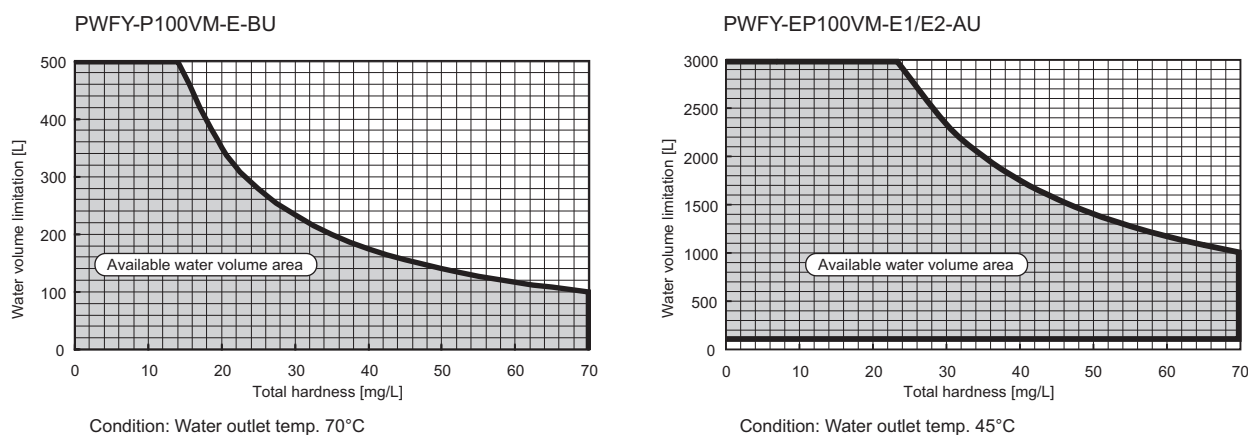

Brine

When PWFY-AU is used under the conditions described in 15-6-2. and 15-6-3. Brine is required to add.

Set Dip SW 1-10 (on ATW unit) to ON if brine is added.

PWFY-P-VM-E-BU, EP-VM-E1-AU, EP-VM-E2-AU

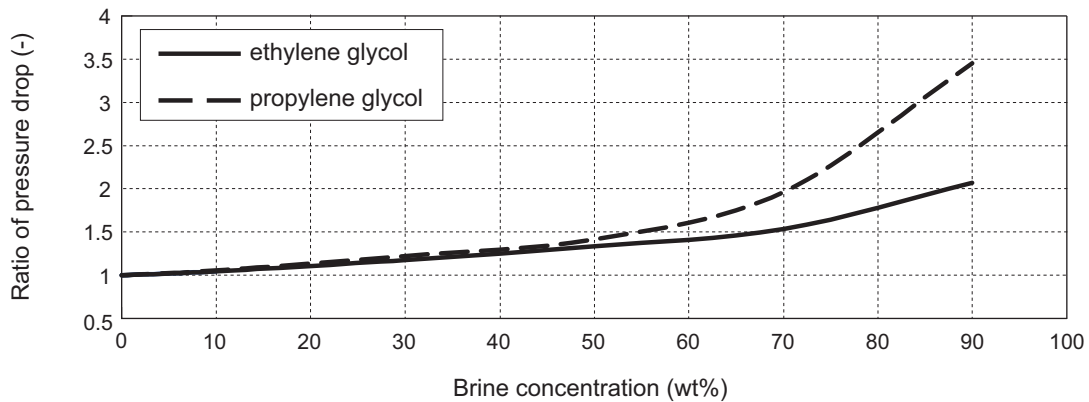
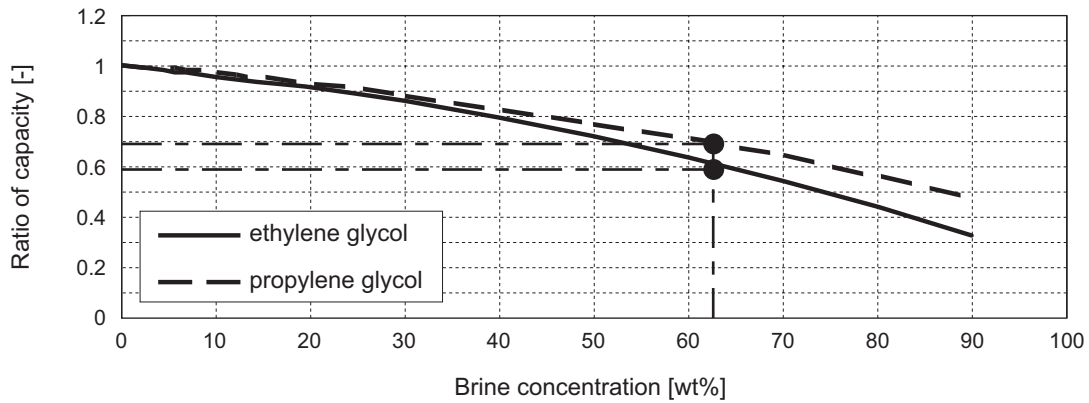
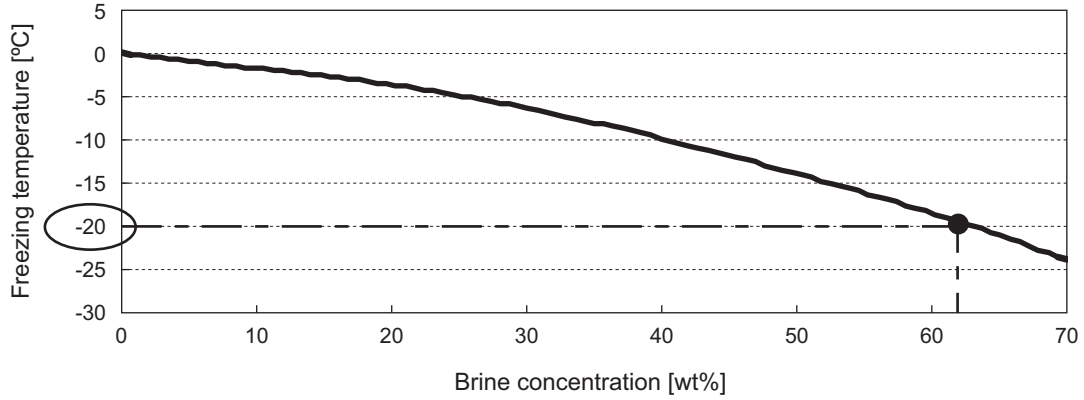

Pump interlock

The unit may become damaged if it is operated with no water circulating through the pipes. Be sure to interlock unit operation and the water-circuit pump.
 In the system including PWFY-P100VM-E-BU, use the terminal blocks for interlocking TB142A (IN1) that can be found on the unit.

[Fig. 3-1-E]

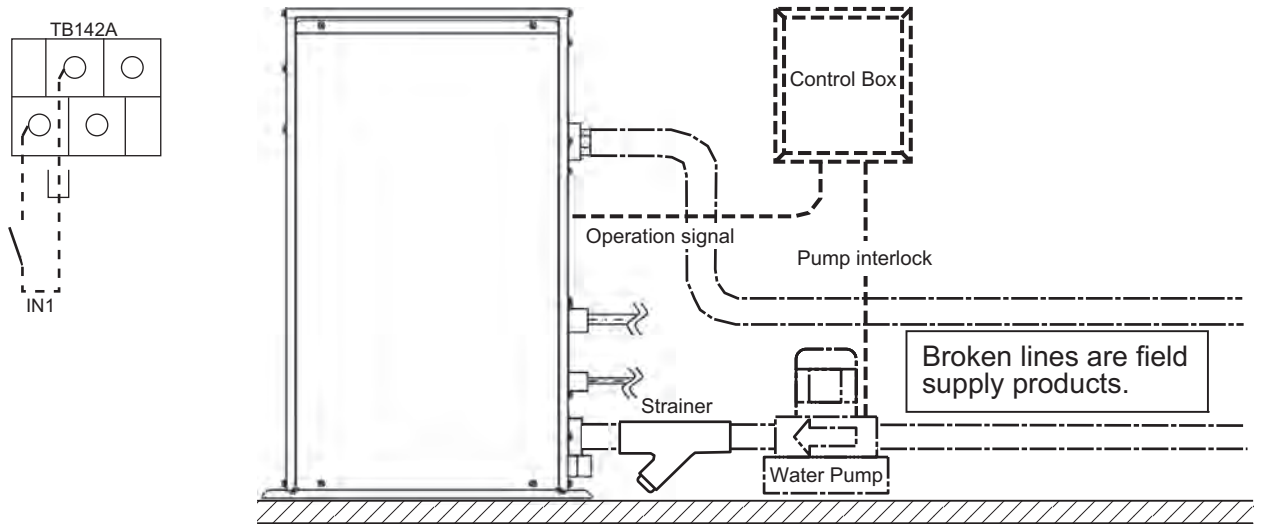

Example drawing for pump interlock

In the system including PWFY-EP100VM-E1/E2-AU, the circulating water may freeze, and result in a unit malfunction. Perform the electrical work as shown in [Fig. 3-1-F] to prevent water from freezing. Set the Dip SW as shown in the table below.

DipSW3-6	External output contact
ON	Effective when Thermo-ON
OFF	Effective when Operation-ON (Remote controller-ON)

Be sure to turn on the power supply of the pump, since the control does not work if the power supply of the pump is turned off.

*Refer to P59 "Flow switch installation" for details.

[Fig. 3-1-F]

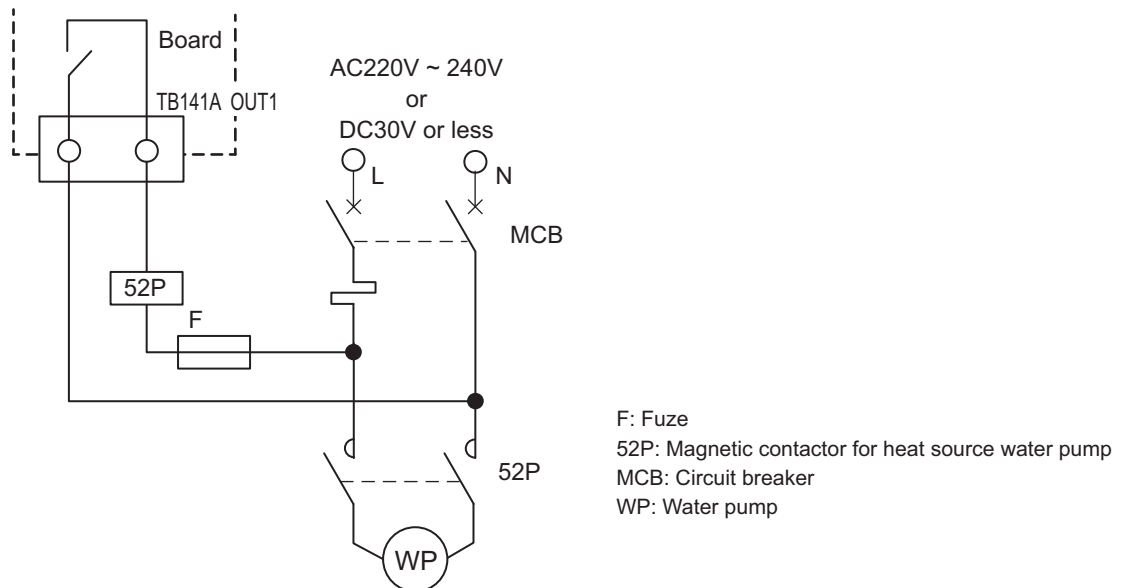

- F: Fuze
- 52P: Magnetic contactor for heat source water pump
- MCB: Circuit breaker
- WP: Water pump

In a system that includes PWFY-EP100VM-E1-AU, if the operation of the pump is interlocked with the operation of the air conditioning units AND if the Solenoid valve kit (PAC-SV01PW-E) is connected to the system, connect the wires as shown in [Fig. 3-1-G]. Set Dip SW3-6 to ON, and make sure that the version of the software is 1.18 or later. (PWFY-EP100VM-E2-AU do not need a solenoid valve kit because they are built in with the same functions.)

[Fig. 3-1-G]

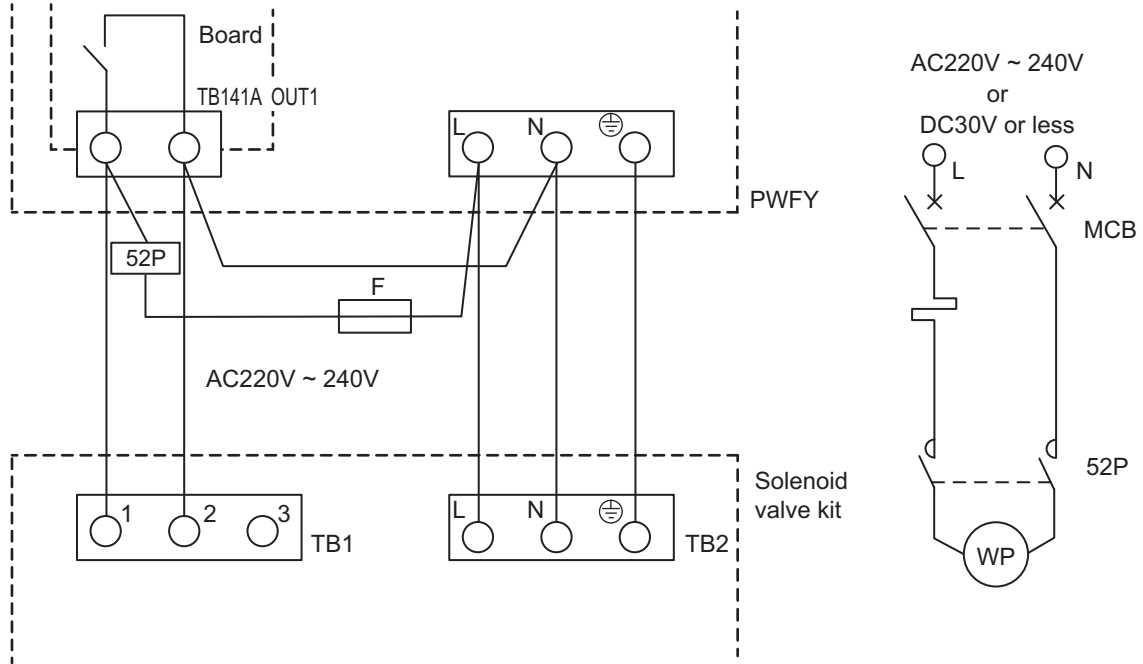

F: Fuze
 52P: Magnetic contactor for heat source water pump
 MCB: Circuit breaker
 WP: Water pump

Anti freeze mode (Dip SW4-4 ON)

Anti freeze mode is to prevent water pipe from freezing. The Anti freeze mode can set the heating temperature range between 10°C~45°C enabling the unit to maintain low water temperature to prevent water pipes from freezing.

PWFY-P-VM-E-BU, EP-VM-E1-AU, EP-VM-E2-AU



for a greener tomorrow

Eco Changes is the Mitsubishi Electric Group's environmental statement, and expresses the Group's stance on environmental management. Through a wide range of businesses, we are helping contribute to the realization of a sustainable society.

⚠ Warning

- Do not use refrigerant other than the type indicated in the manuals provided with the unit and on the nameplate.
 - Doing so may cause the unit or pipes to burst, or result in explosion or fire during use, repair, or at the time of disposal of the unit.
 - It may also be in violation of applicable laws.
 - MITSUBISHI ELECTRIC CORPORATION cannot be held responsible for malfunctions or accidents resulting from the use of the wrong type of refrigerant.
- Our air conditioning equipment and heat pumps contain a fluorinated greenhouse gas, R134a or R410A depending on the product.

MITSUBISHI ELECTRIC CORPORATION