



# CYLINDER UNIT OPTIONAL PARTS IMMERSION HEATER (1Ph 3kW) PAC-IH03V-E

## INSTALLATION MANUAL

- Before starting installation, read the following description together with the installation manual included with the cylinder unit.
- Please read carefully and observe fully the following safety precautions.

**WARNING** Precaution that must be observed to prevent injuries or death.

- After installation carry out a test run to ensure correct operation, then explain operation method and safety precautions to the end user.
- Tell your customers to keep this installation manual together with the operation manual, and when they give or sell this machine to any other person include this installation manual and operation manual with it.

**WARNING**

- If the cylinder has already been connected to the power supply ensure circuit breaker is off before carrying out electrical work.
- If the immersion heater is installed incorrectly or modified after installation by the user water leakage, electric shock or fire may result.
- All electrical work should be performed by a qualified technician according to local regulations and the instructions given in this manual.
- The immersion heater must be powered by a dedicated power supply and the correct voltage and correctly sized circuit breakers must be used.
- Connections must be made securely and without tension on the terminals.

The included component parts of the PAC-IH03V-E IMMERSION HEATER (1Ph 3kW) shall be used only for the purposes indicated in the installation manual.

### Contents

Item	Piece
① Immersion heater	1
② Thermostat (High limit thermal cut-out)	1
③ Tab cover	1
④ Earth leakage breaker	1
⑤ Screw (4×25)	2
⑥ Relay	1
⑦ Screw (4×16)	2
⑧ Label (for Earth leakage breaker)	1
⑨ Label (for Relay)	1
⑩ Lead wire with connector	1
⑪ Lead wire (Red, 100mm)	1
⑫ Lead wire (Blue, 100mm)	1
⑬ Lead wire (Red, 1500mm)	1
⑭ Lead wire (Blue, 1500mm)	1
⑮ Water-proof cover	1
⑯ Water-proof seal (3x35x25)	1
⑰ Water-proof seal (3x40x25)	1
⑱ Band	1
⑲ Tool	1
⑳ Installation manual	1

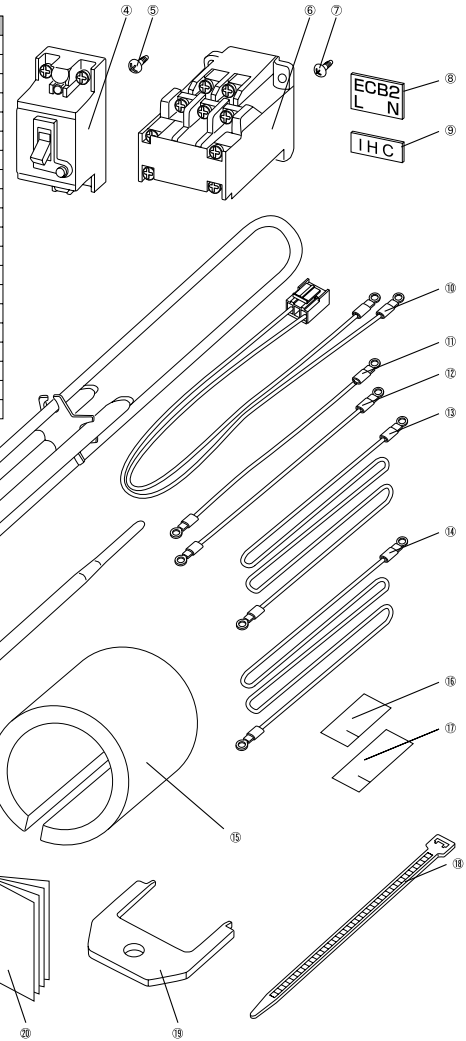

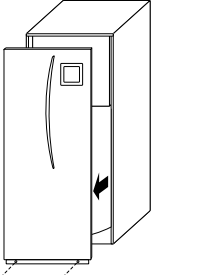
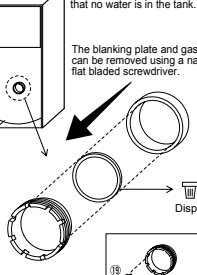
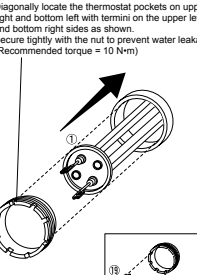
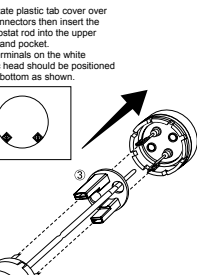
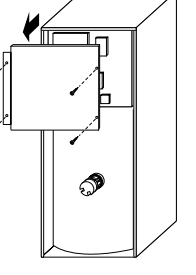
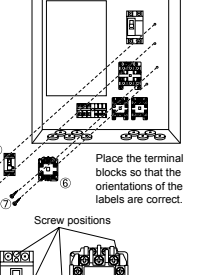
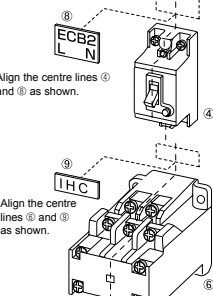
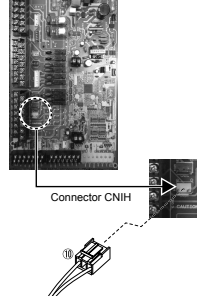
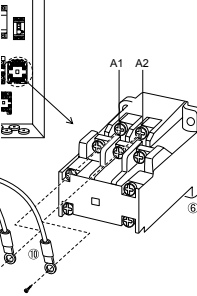
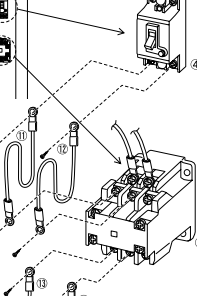
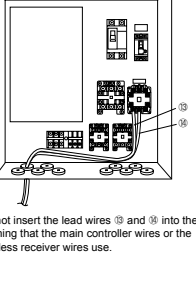
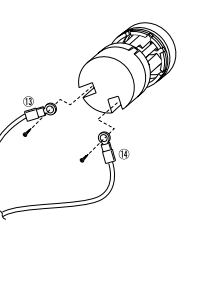
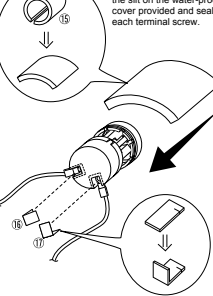
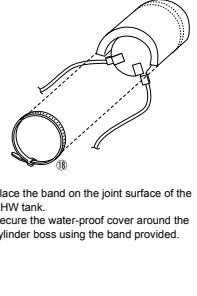
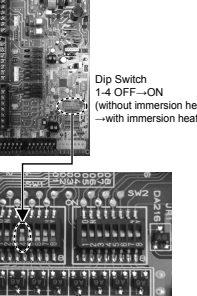
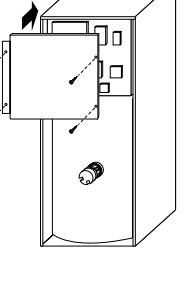
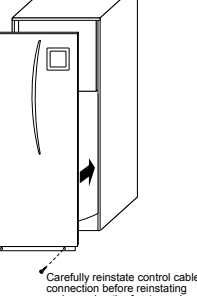
<p><b>1</b></p>  <p>Carefully remove front panel by disconnecting the control cable from beneath the unit's main control box.</p>	<p><b>2</b></p>  <p>Check before starting installation that no water is in the tank.</p> <p>The blanking plate and gasket can be removed using a narrow flat bladed screwdriver.</p> <p>Dispose</p>	<p><b>3</b></p>  <p>Diagonally locate the thermostat pockets on upper right and bottom left with termini on the upper left and bottom right sides as shown.</p> <p>Secure tightly with the nut to prevent water leakage. (Recommended torque = 10 N·m)</p>	<p><b>4</b></p>  <p>Reinstate plastic tab cover over the connectors then insert the thermostat rod into the upper right hand pocket.</p> <p>The terminals on the white plastic head should be positioned at the bottom as shown.</p> <p>Assemble 2 and 3 securely.</p>	<p><b>5</b></p> 	<p><b>6</b></p>  <p>Place the terminal blocks so that the orientations of the labels are correct.</p> <p>Screw positions</p>
<p><b>7</b></p>  <p>Align the centre lines ④ and ⑤ as shown.</p> <p>Align the centre lines ⑥ and ⑦ as shown.</p>	<p><b>8</b></p>  <p>Connector CN1H</p>	<p><b>9</b></p>  <p>A1 A2</p>	<p><b>10</b></p> 	<p><b>11</b></p>  <p>Do not insert the lead wires ⑩ and ⑪ into the opening that the main controller wires or the wireless receiver wires use.</p>	<p><b>12</b></p> 
<p><b>13</b></p>  <p>Run the lead wire through the slit on the water-proof cover provided and seal each terminal screw.</p>	<p><b>14</b></p>  <p>Place the band on the joint surface of the DHW tank.</p> <p>Secure the water-proof cover around the cylinder boss using the band provided.</p>	<p><b>15</b></p>  <p>Dip Switch 1-4 OFF → ON → with immersion heater</p>	<p><b>16</b></p> <p>For details about wiring to power supply and circuit breaker, refer to the installation manual for the cylinder unit.</p> <p>Fill tank with water and ensure that no water leaks around the periphery of the immersion heater.</p>	<p><b>17</b></p> 	<p><b>18</b></p>  <p>Carefully reinstate control cable connection before reinstating and securing the front panel.</p>