

## SAFTY PRECAUTIONS

- Before starting installation, read the "Safety Precautions" described below.
- The following precautions must be observed as it describes the serious matters for safety.
- The safety precautions are described with the degree of danger.

<b>⚠ WARNING</b>	When you handle wrong, it can lead to death or serious injury.
<b>⚠ CAUTION</b>	When you handle wrong, it can lead to injury or damage to building and furniture.

- After installation, make test operation and confirm that it works properly, and explain the safety precautions, operation method, and maintenance to your customers. Tell your customers to keep this installation manual together with operation manual with them, and when they give or sell this machine to other person put this installation manual and operation manual with it.

### ⚠ WARNING

**The installation must be done by dealer or qualified person.**

- If the customers do the installation by themselves and it is not perfectly installed it can cause water leak, electric shock, or fire.

**The installation must be done in accordance with this manual.**

- If the installation is not perfectly done, it can cause water leak, electric shock, or fire.

**Never try any modification.**

- For repair, ask your dealer. If the machine is modified or repaired imperfectly, it can cause water leak, electric shock, or fire.

**Never move or reinstall the machine by the customers.**

- If the installation is not perfectly done, it can cause water leak, electric shock, or fire. Ask your dealer or qualified person.

**The wiring must be securely done by using proper cable. The wires should be connected to the terminals not to have external force of the cable.**

- Unperfect connections can cause heat or fire.

**The terminal cover (panel) of the unit must be installed securely.**

- Unperfect installation can cause fire or electric shock by dust or water.

**The electric installation must be done by qualified person in accordance with this installation manual. Use the separate circuit only for this machine and use rated voltage and circuit breaker.**

- If the electric circuit power is not sufficient or the wiring is not properly done, it can cause electric shock or fire.

### Before electric wiring.

#### ⚠ CAUTION

**Install a circuit breaker depending upon the location.**

- Without a circuit breaker, it can cause electric shock.

**Use standard wires which meet current capacity.**

- Otherwise, it can cause short-circuit, heat, or fire.

**Wires must not have tension.**

- It can cause snapping, heat, or fire.

**Put ground wire.**

- Never ground to gas pipe, water pipe, lightning conductor, or telephone ground wire. Unperfect ground can cause short-circuit.

**Use proper fuses**

- If you use larger size fuses or needle wire, it can cause failure or fire.

### Before test operation.

#### ⚠ CAUTION

**Turn the power on 12 hours or more before operation.**

- If you start operation as soon as the power on, it can cause failure. Never turn the power off during season.

**Never operate the machine without panel or guard off.**

- It can cause serious injury being caught by rotating part or burns or electric shock by high voltage part.

**Never operate the machine without air filter off.**

- It can cause failure by dust.

**Never operate the switches with your hand wet.**

- It can cause electric shock.

**Never touch refrigerant pipes while the machine running.**

- The refrigerant pipes becomes high and low temperature while the machine running. If you touch the pipes by hand, it can cause chilblain or burn.

**Never turn the power off as soon as the machine stops.**

- Wait for 5 minutes or more. It can cause water leaks or failure.

### Wiring M-NET communication cable

Earth the shield wire of M-NET communication cable to the terminals of connected devices.

- Failure to do so may result in communication error.  
Outdoor unit digital LED indicator may not light.  
Centralized control remote controller may not operate.

If the shield wire is earthed at two points or more, a circuit current will flow. A potential difference will occur due to the difference in earth resistance, which will cause noise in the shield wire.

If the shield wire is earthed at one point only, the circuit will be open. To prevent communication error due to noise, earth the shield wire at one point.

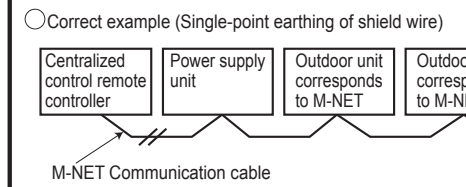
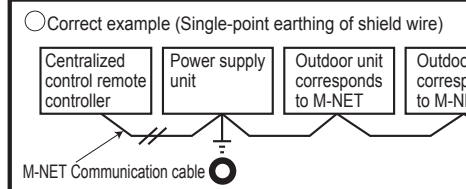
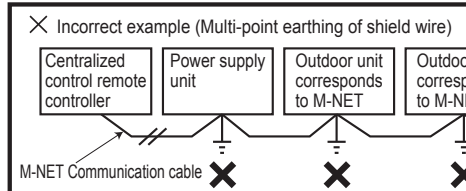

- \* In case that the outdoor unit is grounded, connect the shield wire to the S terminal (second terminal) of the terminal block and M-NET Ground terminal inside of electrical control box using screws supplied.

### 1. Parts list

No.	Description	Figure	Q'ty	No.	Description	Figure	Q'ty
①	M-NET board (with insulation sheets and supports)		1	⑦	Lead wire (5 wires) for signals length: 280mm		1
②	Mounting plate (M-NET board)		1	⑧	Lead wire (3 wires) for power supply length: 300mm		1
③	Screw (M4×8)		2	⑨	Lead wire (M-NET) length: 280mm		1
④	Terminal block (M-NET)		1	⑩	Earth wire and screw (M4×8)		1 each

### 2. Installation procedures [Applicable models]

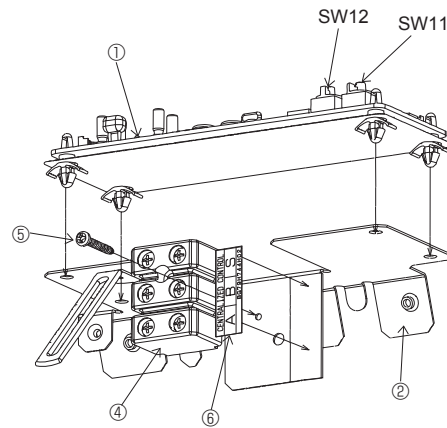

### 3. Wiring method for M-NET

(1) Attention

- ① Outside of the unit, the wires for transmission (called for transmit wires later) should keep away (5 cm or more) from power cable not to receive electric noise. (Never put the transmit wires and power cable in the same cable pipe.)
- ② Never supply voltage 220V-240V to the terminals (TB7) for transmission. If the voltage is supplied, it can break the electronic parts on the M-NET board.
- ③ Use the shielded cable (CVVS, CPEVS) of 1.25mm square thickness with 2 wires for the transmission cable. Never use transmit wires of different system with a cable which contains multi wires. The communication of transmit signals will not work properly and it can cause wrong operation.

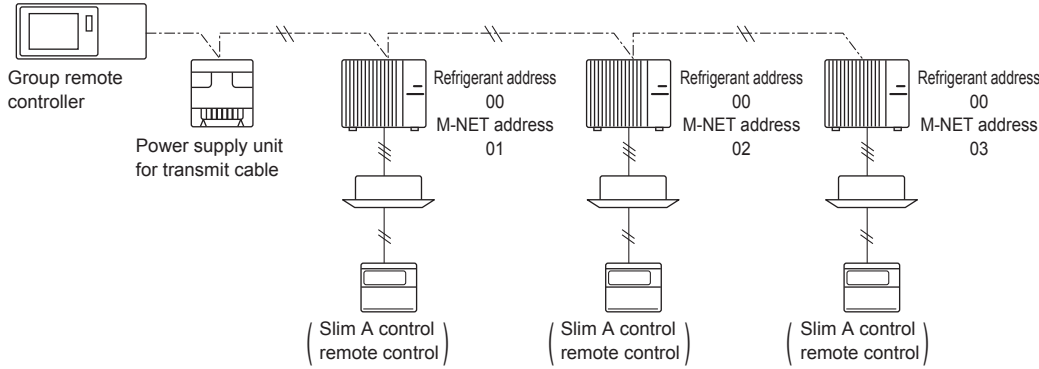

Between the outdoor units, it is OK that only M-NET wiring (2 wires, no polarity) is done.

(2) M-NET address setting

Make M-NET setting and refrigerant address setting on only outdoor unit. There is no address settings for outdoor unit and remote controller like City Multi system. The M-NET address setting for taking into centralized control system should be done only to the outdoor unit. The address set number should be 1-50 same as for City Multi indoor unit and make set in order of number for the same group.

	A control slim	City Multi (M-NET)
Indoor unit	—	1~50
Outdoor unit	1~50	51~100
Remote controller	—	101~150
System controller	201~250	
Group remote controller	201~250	

The setting should be done by rotary switches SW11 (1st digit) and SW12 (2nd digit) on M-NET board of the outdoor unit. (Factory settings are all zero.)

[ Example ]

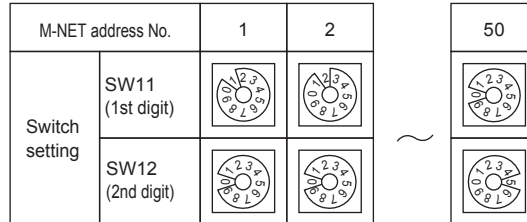

5

(3) Refrigerant address setting

In case that the A control Slim is set for group between outdoor units, it is necessary to make refrigerant address setting on each outdoor unit. In case that the group setting is not done, be sure to leave the dip switch SW1 (3-6) on the outdoor controller of the outdoor unit OFF. Factory settings are all OFF (Refrigerant address 00).

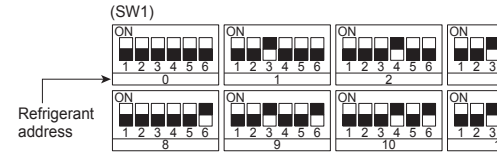

(4) Limitation for address settings

In case of group operation, the M-NET address settings should be done according to the procedure above. However, make the minimum M-NET address 01 and refrigerant address 00.

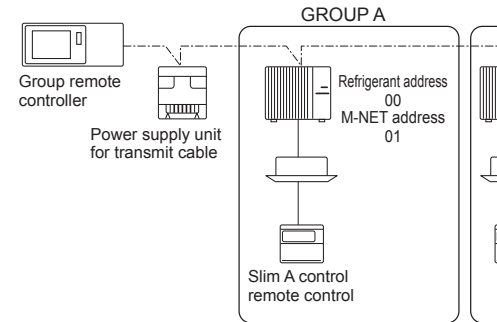

※It does not matter if the refrigerant address settings are different in the group.

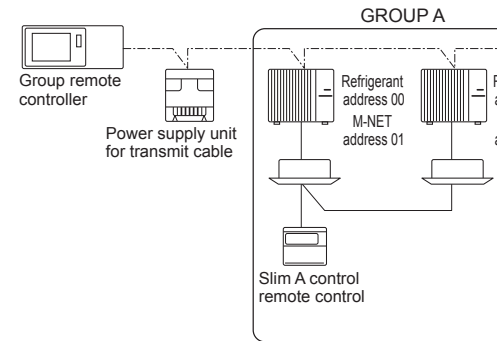

※ It is not good with the above setting in the group B because the outdoor units in group B will not have the minimum M-NET address 3 in the group. Make the minimum M-NET address in the group like the group A.

(5) Switch 1-2 setting

SW1-2 Selection	Function	Function details	Initial setting	Effective timing
<p>ON</p> <p>SW1</p> <p>■ is the switch position.</p>	<p>Turn the switch ON when MA remote controller or wireless remote controller is connected to indoor unit.</p> <p>converter: M-NET board MA RC : MA remote controller RC : wireless remote controller</p>	<p>&lt;FUNCTION&gt; Set the connection of MA-remote controller or wireless remote controller to the indoor unit. ON : exist (initial setting) OFF : not exist</p>	ON	Always
OFF	<p>Turn the switch OFF when MA remote controller or wireless remote controller is NOT connected to indoor unit.</p>	<p>&lt;NOTE&gt; In case of switch is ON, transmission apparatus must be connected to indoor unit.</p>		