

LOSSNAY

HANDBOOK

Model : VL-100U5-E
VL-100EU5-E

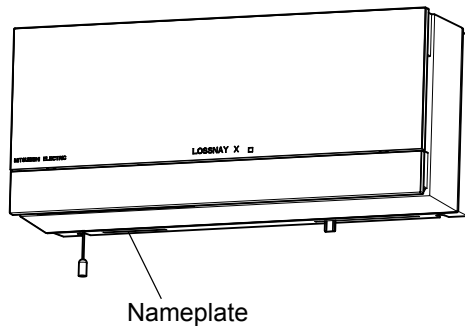









Repair work must be performed by the manufacturer, its service agent or a similarly qualified person in order to avoid hazards.



Contents

1. Safety precautions	3
2. Names and functions of components	4
3. Specifications	4
4. Outside dimensions	5
5. Electrical wiring diagrams	6
6. Troubleshooting	7-8
7. How to call	9
8. Service inspection list	9
9. Overhauling procedures	10-15
10. Parts catalog	16-24
VL-100U5-E	17-20
VL-100EU5-E	21-24

1. Safety precautions

- Read the following precautions thoroughly before the maintenance, and then inspect and repair the product in a safe manner.
- The types and levels of danger that may arise if the product is handled incorrectly are described with the warning symbols shown below.

 Warning		Incorrect handling of the product may result in serious injury or death.	
<p>◇ Electric shock If you must inspect the circuitry while the power is on, do not touch the live parts.</p> <p>(Failure to heed this warning may result in electric shock.)</p>	 <p>Caution against electric shock</p>	<p>◇ Turn off the power supply Be sure to unplug the power cord, or shut off the circuit breaker before disassembling the unit for repair.</p> <p>(Failure to heed this warning may result in electric shock.)</p>	 <p>Be sure to follow this instruction.</p>
<p>◇ Modification is prohibited Do not modify the unit.</p> <p>(Failure to heed this warning may result in electric shock, fire and/or injury.)</p>	 <p>Prohibited</p>	<p>◇ Use proper parts and tools For repair, be sure to use the parts listed in the service parts list of the applicable model and use the proper tools.</p> <p>(Failure to heed this warning may result in electric shock, fire and/or injury.)</p>	 <p>Be sure to follow this instruction.</p>
<p>◇ Proper electric work Use the electric wires designated for electric work, and conduct electric work in accordance with the "Electric Installation Engineering Standard", the "Indoor Wiring Regulations" and the installation instructions.</p> <p>(Improper connection or wiring installation may result in electric shock and/or fire.)</p>	 <p>Be sure to follow this instruction.</p>	<p>◇ Replace damaged and/or degraded parts Be sure to replace the power cord and lead wires if they are damaged and/or degraded.</p> <p>(Failure to heed this warning may result in electric shock and/or fire.)</p>	 <p>Be sure to follow this instruction.</p>
		<p>◇ Check insulation Upon completing repair work, always measure the insulation resistance. Verify that it is at least 10 MΩ (with a 500 V DC insulation resistance tester), and then turn on the power.</p> <p>(Inadequate insulation may result in electric shock.)</p>	 <p>Be sure to follow this instruction.</p>

 Caution		Incorrect handling of the product may result in injury or damage to properties including buildings and equipment.	
<p>◇ Caution for injury Do not work at a location where you do not have a sure footing.</p> <p>(Failure to heed this caution may result in a fall.)</p>	 <p>Prohibited</p>	<p>◇ Wear gloves Wear gloves when servicing.</p> <p>(Failure to heed this caution may result in injury to your hands from sharp metal or other edges.)</p>	 <p>Be sure to follow this instruction.</p>



Request for repair

- Inspect the grounding, and repair it if it is incomplete. Make sure that a power supply isolator or an overload protection device is installed, if it is not installed, recommend the dealer to install one.
- Make sure that the product operates properly upon completion of repair. Clean the product and the surrounding area, and then notify the customer of the completion of repair.

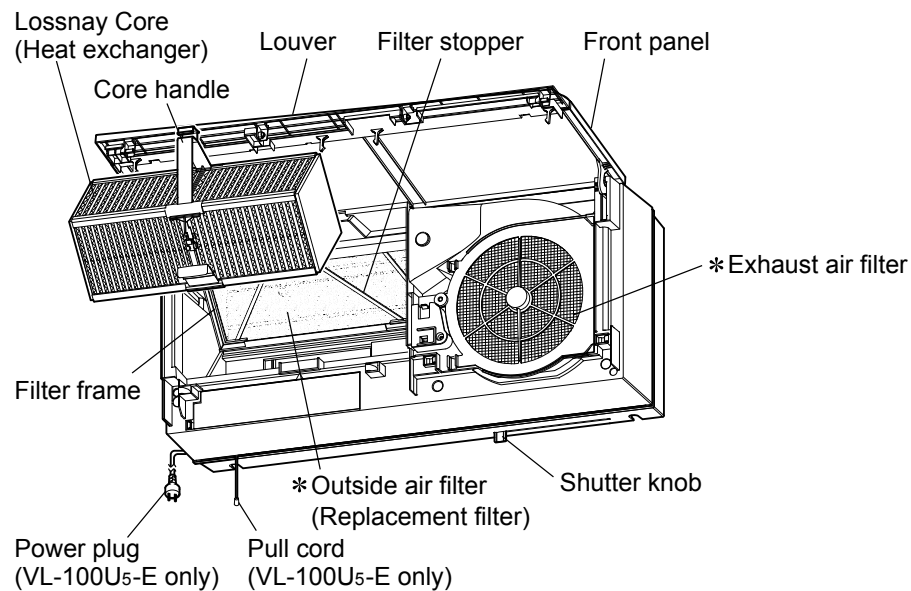
2. Names and functions of components

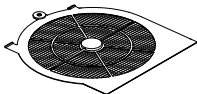

* About the filters

			Features
Exhaust air filter		Exhaust air side	The filter prevents clogging of the internal parts.
Outside air filter (Replacement filter)	 (P-100F5-E: Optional parts)	Supply air side	When Lossnay takes in outside air to a room, the filter collects dust, sand, pollen or the likes from outside air. Note: Some fine particles or tiny insects may pass through the filter. The high performance filter is recommended for higher collecting effect.

Outside air filter can be replaced with the following high performance filter.

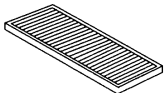
High performance filter (Optional parts)	 (P-100HF5-E)	Supply air side	The filter collects dust more efficiently than the outside air filter. Note: When using the high performance filter, install it in the filter frame without using the filter stopper.
---	---	-----------------	--

3. Specifications

Model	Power supply		Notch	Power consumption (W)	Air volume (m ³ /h)	Temperature exchange efficiency (%)	Sound level (dB)	Weight (kg)
	Frequency (Hz)	Voltage (V)						
VL-100U5-E VL-100EU5-E	50	220	Hi	30	100	73	36.5	7.5
			Lo	13	55	80	24	
		230	Hi	31	105	73	37	
			Lo	15	60	80	25	
		240	Hi	34	106	72	38	
			Lo	17	61	79	27	
	60	220	Hi	34	103	73	38	
			Lo	17	57	80	25	

* The testing methods are based on Japanese Industrial Standard B 8628.

4. Outside dimensions

VL-100U₅-E

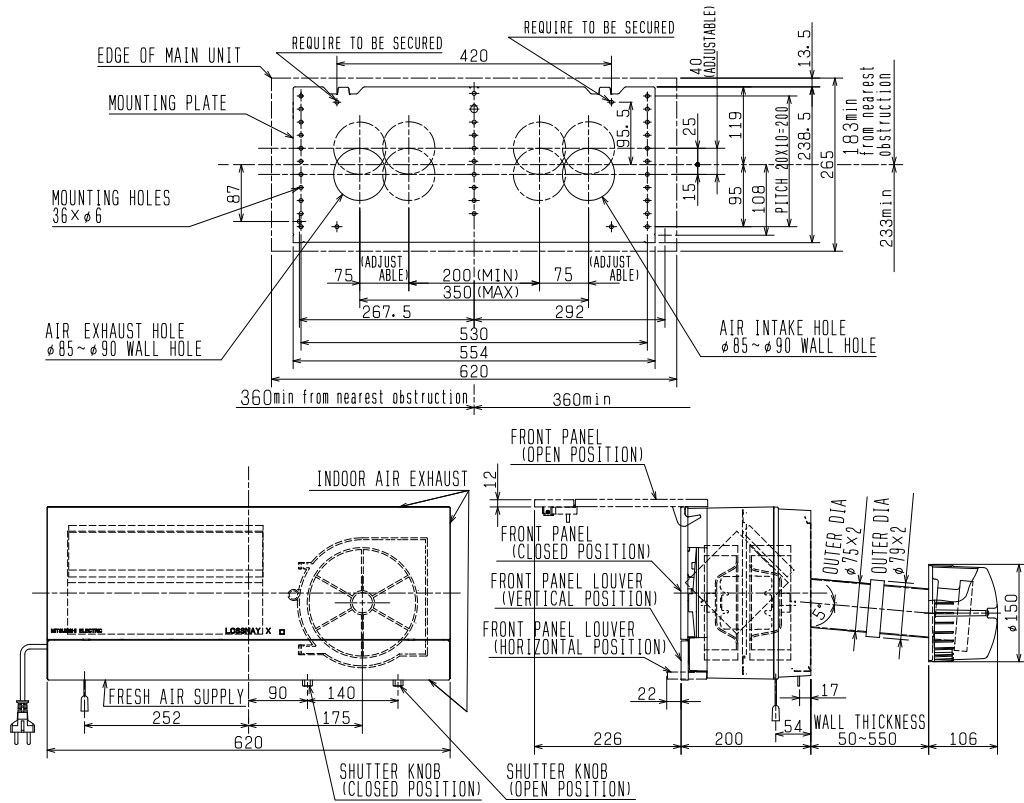

Unit (mm)

VL-100EU₅-E

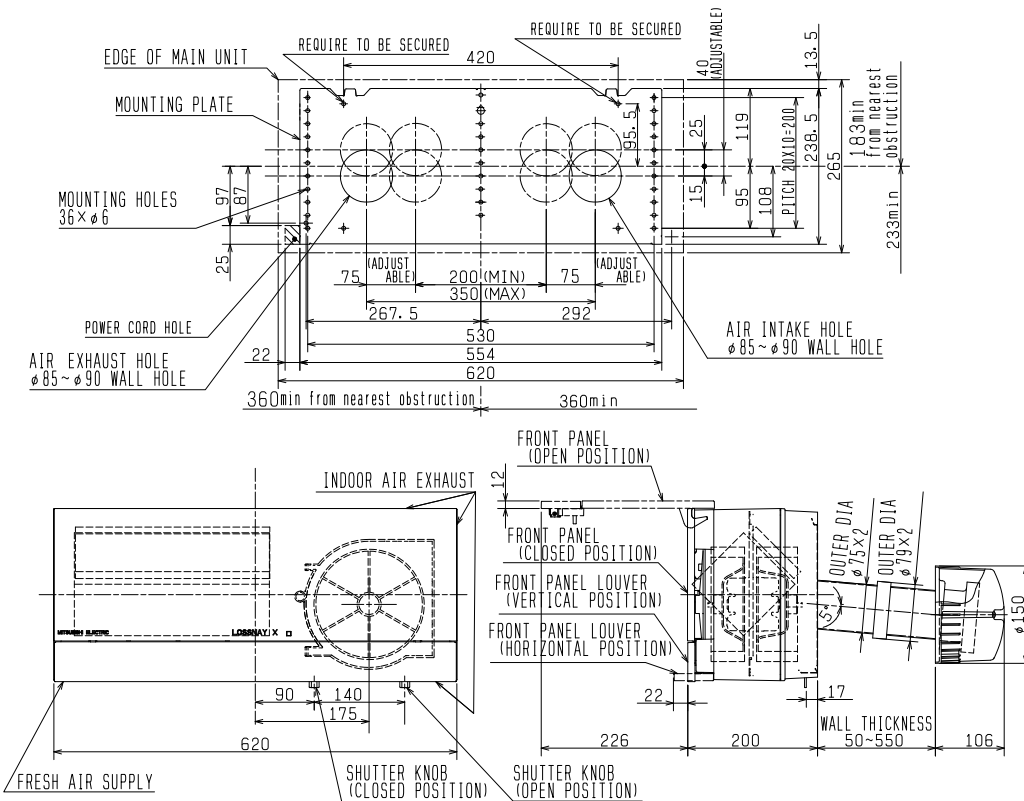

Unit (mm)

5. Electrical wiring diagrams

VL-100U₅-E

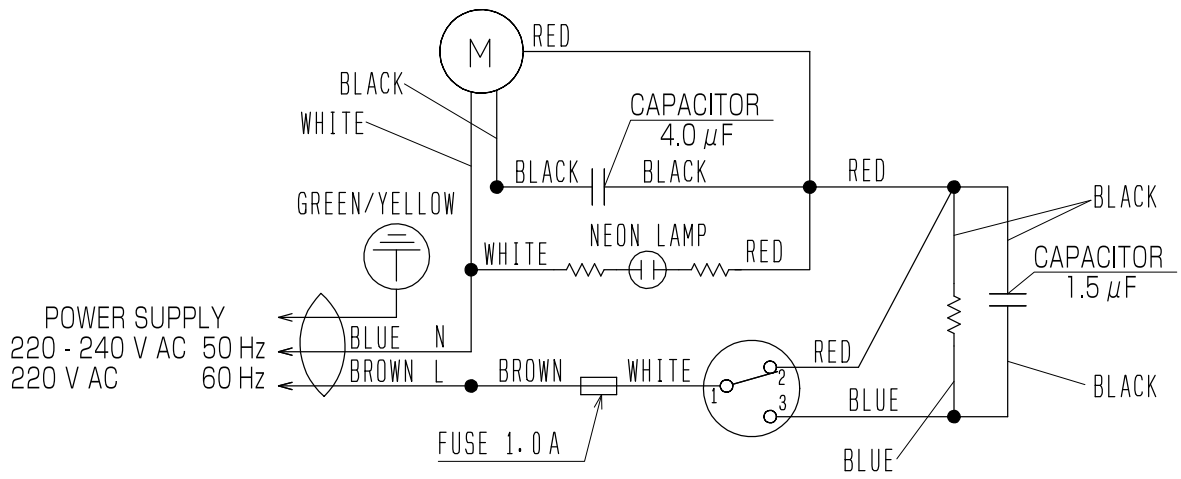

VL-100EU₅-E

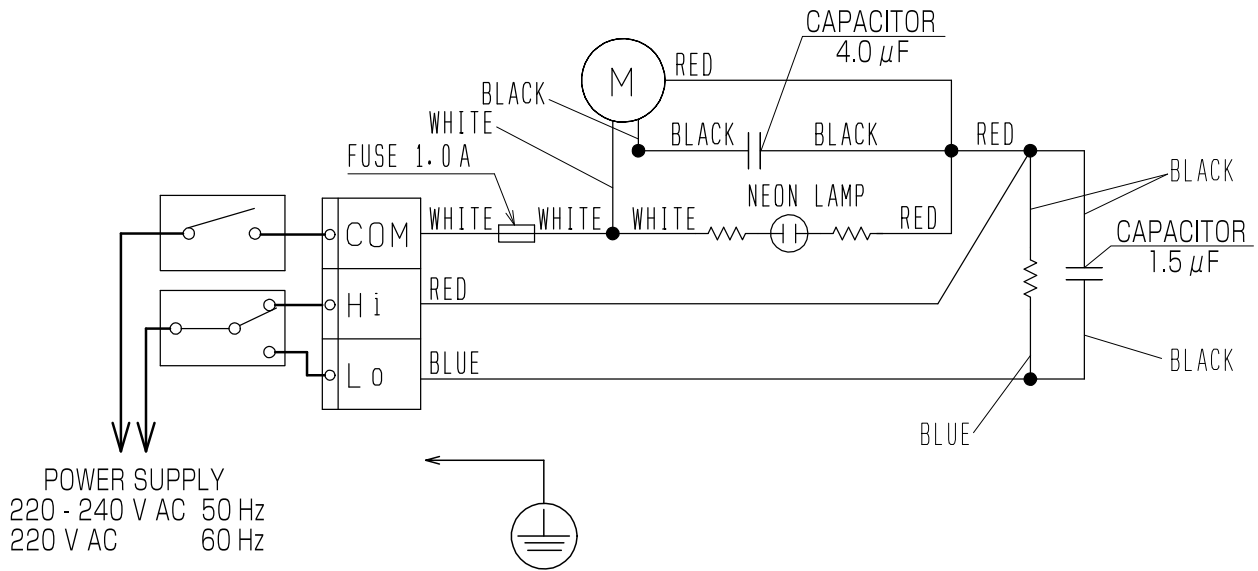

6. Troubleshooting

■ Work precautions

- When servicing, be sure to recreate the malfunction two or three times before starting repairs.
- When servicing, always keep proper footing.
- When servicing, always unplug the power cord from the outlet, or turn off the circuit breaker. Sufficient care must be taken to avoid electric shock or injury.
- Always connect the power wires properly.

(1) Service Flowchart

After checking the check items below, follow the troubleshooting 1 and 2 for servicing.

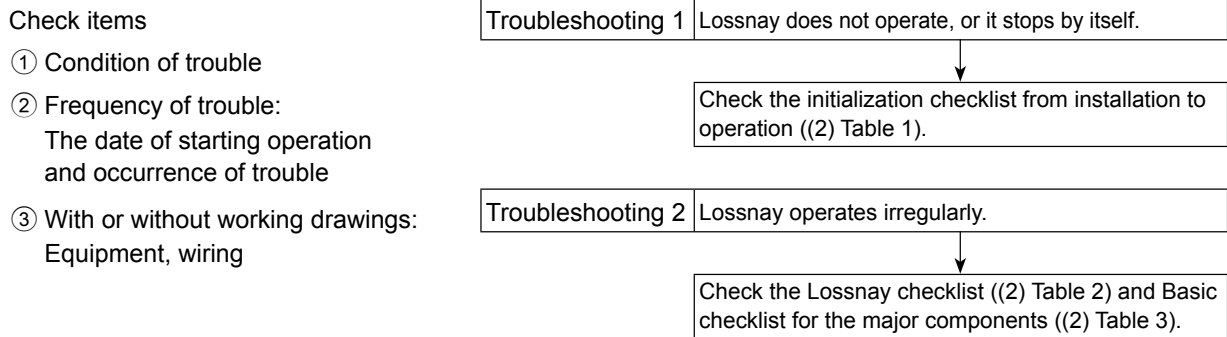

(2) Checklist

Troubleshooting 1	Lossnay does not operate, or it stops by itself.
-------------------	--

① Initialization checklist from installation to operation (Table 1)

No.	Error	Checkpoint
1	The Lossnay operation is disabled or improper. Lossnay stops irregularly.	Check the main power connection. <For VL-100U ₅ -E> • Is the power plug connected to the power supply of rated voltage? <For VL-100EU ₅ -E> • Is the rated voltage supplied to the terminal block? • Is there a poor connection?

Troubleshooting 2	Lossnay operates irregularly.
-------------------	-------------------------------

② Lossnay checklist (Table 2)

No.	Error	Cause	Action
1	The shutter does not open. The shutter does not close.	Is there any foreign matter or obstruction around the shutter?	Remove it.
2	The fan does not rotate.	Do the fan blades touch other parts?	Check for an abnormal area. Replace the parts of the abnormal area.
		Is there any foreign matter around the fan?	Remove it.
		Is there something wrong with the motor?	Check the basic checklist for the major components (Table 3).
3	An unusual noise comes from the fan.	Is there any foreign matter around the fan?	Check around the fan.
		Can you rotate the fan manually?	No: Replace the motor.
		Is there an odd feeling when rotating the fan?	Yes: Replace the motor.

No.	Error	Cause	Action
3	An unusual noise comes from the fan.	Is there something wrong with the motor?	Check the basic checklist for the major components (Table 3). Replace the abnormal parts.
4	High/Low lamp does not illuminate.	Is Lossnay operating at the High or Low fan speed?	If the lamp does not illuminate during the High or Low fan speed operation, replace the neon lamp.

③ Basic checklist for the major components (Table 3)

*Make sure to unplug the power cord or turn off the circuit breaker, before performing the procedures No. 2 to 4.

No.	Parts	Judging instructions								
1	—	Check that the fan rotate while the rated voltage is supplied.								
2	Fuse	Check if the fuse is blown out. If the fuse is blown out, replace the fuse.								
3	Switch with a pull cord (VL-100U ₅ -E only)	Remove the switch from the main unit. Measure the resistance at the weld for the wire connection on the backside of the switch. If the resistance differs from the value listed below, replace the switch. <table border="1" style="margin-left: auto; margin-right: auto;"> <thead> <tr> <th>Color of wires</th> <th>Notch</th> <th>Resistance</th> </tr> </thead> <tbody> <tr> <td>White - Red</td> <td>High</td> <td rowspan="2">Approx. 0.1 Ω (conducted)</td> </tr> <tr> <td>White - Blue</td> <td>Low</td> </tr> </tbody> </table>	Color of wires	Notch	Resistance	White - Red	High	Approx. 0.1 Ω (conducted)	White - Blue	Low
Color of wires	Notch	Resistance								
White - Red	High	Approx. 0.1 Ω (conducted)								
White - Blue	Low									
4	Motor	<p><For VL-100U₅-E> Measure the resistance between the pins of the power plug.</p> <p><For VL-100EU₅-E> Measure the resistance between C and Hi (High), and between C and Lo (Low) terminals of the terminal block.</p> <ul style="list-style-type: none"> • If the resistance differs from the value listed below, replace the motor and capacitors. • If the resistance is approximately equal to the value listed below, replace the capacitors. <table border="1" style="margin-left: auto; margin-right: auto;"> <thead> <tr> <th>Notch</th> <th>Resistance</th> </tr> </thead> <tbody> <tr> <td>High</td> <td>Approx. 490 Ω</td> </tr> <tr> <td>Low</td> <td>Approx. 0.1 Ω</td> </tr> <tr> <td>OFF (VL-100U₅-E only)</td> <td>Open</td> </tr> </tbody> </table>	Notch	Resistance	High	Approx. 490 Ω	Low	Approx. 0.1 Ω	OFF (VL-100U ₅ -E only)	Open
Notch	Resistance									
High	Approx. 490 Ω									
Low	Approx. 0.1 Ω									
OFF (VL-100U ₅ -E only)	Open									

7. How to call

Symptom	Remedy
The incoming air feels cold.	① Stop the operation, and close the shutter. ② Adjust the louver in a horizontal position. ③ Change the fan speed to Low.
Unusual noise occurs. (Noise became louder.)	① Clean the filters. ② Securely attach the front panel and filters.
Small insects intrude into the unit.	① Place the filter (outside air filter) properly inside the filter frame. ② Replace the filter (outside air filter) with the high performance filter (optional parts).

8. Service inspection list

Location	Inspection Item	Check Result
Electric wiring	Are the power lead wires securely connected to the terminal block? (VL-100EU ₅ -E)	
	Is the wiring correct? (VL-100EU ₅ -E)	
Appliance	Is the main unit securely mounted?	
	Does Lossnay operate as described in the Operating Instructions when operating the switch?	
	Is the fan operating?	
	Does the shutter work?	
	Does Lossnay operate without abnormal vibration or noise?	

9. Overhauling procedures

■ Work precautions

- Before replacing parts, follow the instructions described in the troubleshooting.
- When servicing, always keep proper footing.
- When servicing, always unplug the power cord from the outlet, or turn off the circuit breaker. Sufficient care must be taken to avoid electric shock or injury.
- Always connect the power wires properly.
- After completing repairs, verify that the product operates properly.
- Always wear gloves when servicing.

(1) Turning power off

- ① Stop the operation by the switch.
- ② Unplug the power cord from the outlet, or turn off the circuit breaker.

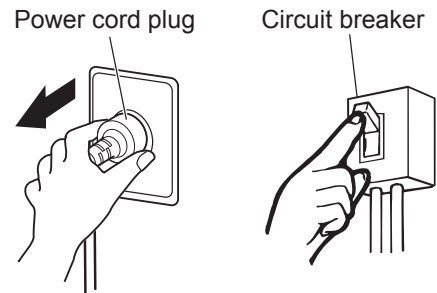

(2) Power lead wires to the terminal block

For VL-100EU5-E

- ① Open the front panel.

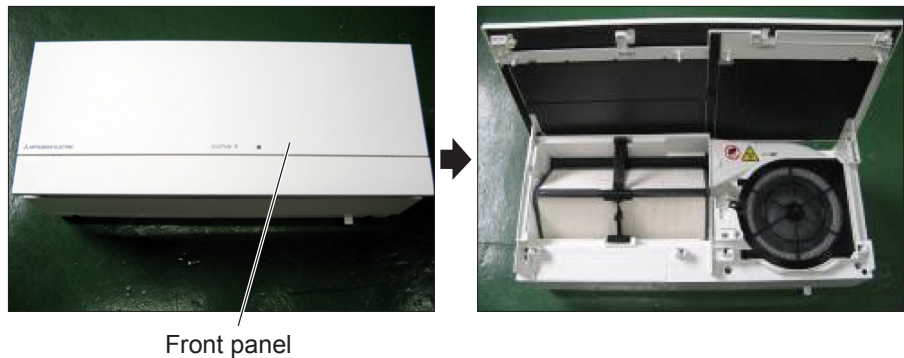

- ② Unhook the claw of the cover, and remove the cover.

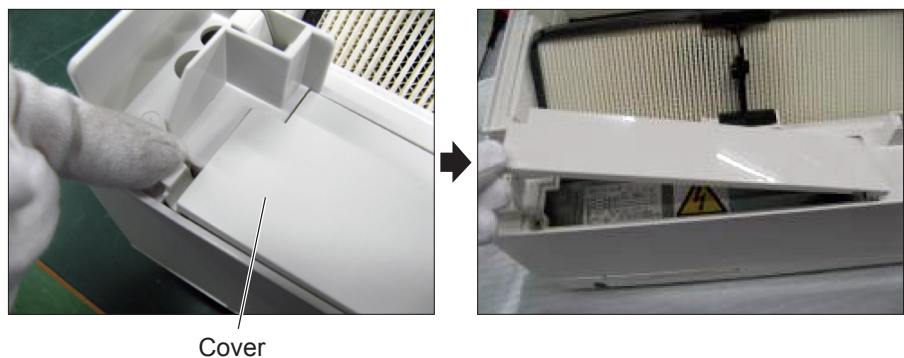

- ③ Unscrew the terminal block (TB) case cover clamping screw (one PT screw 4 × 8, indicated by ○), and remove the TB case cover.

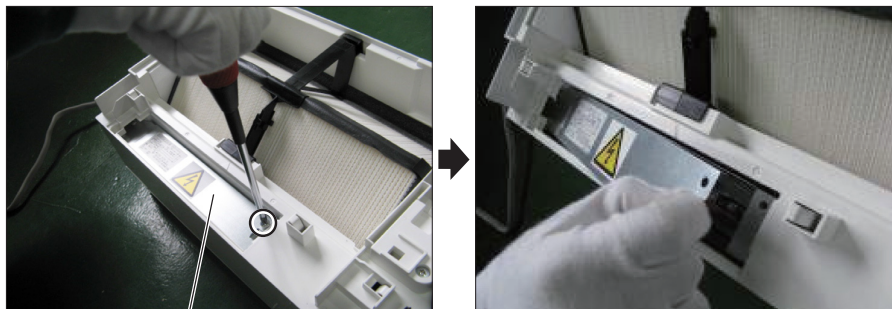

TB case cover

- ④ Loosen the screws of the terminal block (three screws, indicated by ○) with a screwdriver, and disconnect the power lead wires.

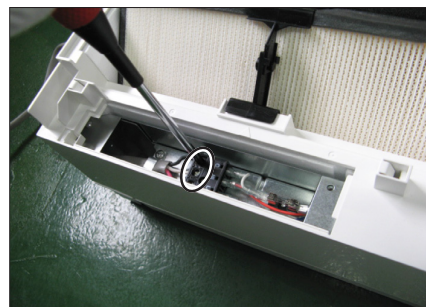

(3) Main unit

- ① Unscrew the main unit clamping screws (two black PTT screws 4 × 8, indicated by ○).
- ② Slightly lift the main unit, and then take it down.

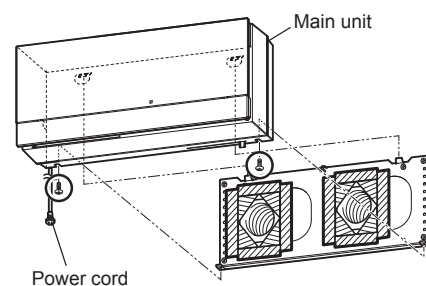

*The illustration shows VL-100U5-E.

(4) Front panel

- Open the front panel all the way (approx. 90 degrees), and pull it up to unhook the claws (indicated by ○).

Precaution
Pay attention not to damage the front surface of the removed panel.



(5) Lossnay core

- Hold the core handle, and pull it out in the direction of the arrow while holding down the hook part.

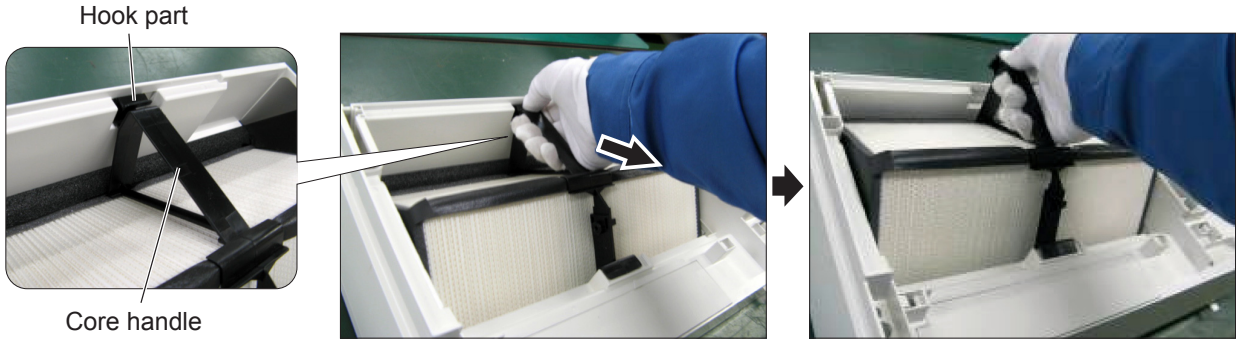

<Reassembly procedure>

- When installing the Lossnay core, first fit the lower part of the core handle (indicated by "a") into "b" position of the front casing, and then hook the ledge of the core handle to the concave portion of the front casing (indicated by □).



Reassembly precaution
Check that both edges of the Lossnay core (indicated by ○) are securely fitted.



(6) Front casing

- ① Unscrew the screws (six PTT screws 4 × 14, indicated by ○).

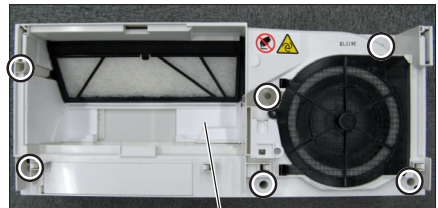

Front casing

- ② Unscrew the lamp cover clamping screw (one PTT screw 4 × 14, indicated by ○), and remove the lamp cover.



Lamp cover

- ③ Remove the neon lamp from the front casing.
- ④ Pass the neon lamp through the hole of the front casing, and then remove the front casing.

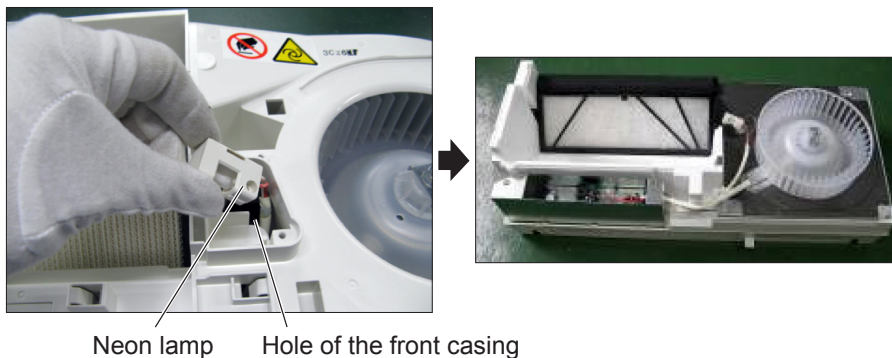

(7) Air exhaust (EA) fan

- ① Remove the special nut (8) and tab washer, and then remove the EA fan.

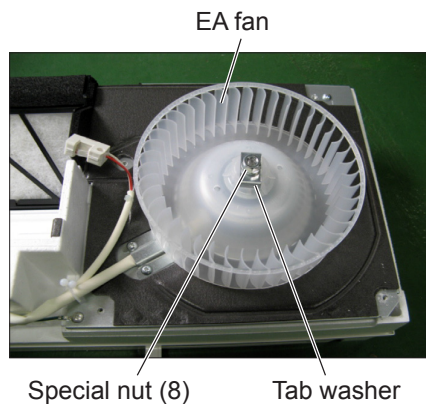

- ② Remove the special (spl) washer (40 mm in outer diameter).

Reassembly precaution
 Be aware of the size difference between each washer for EA fan and SA fan.
 Incorrect installation may cause unusual noise.

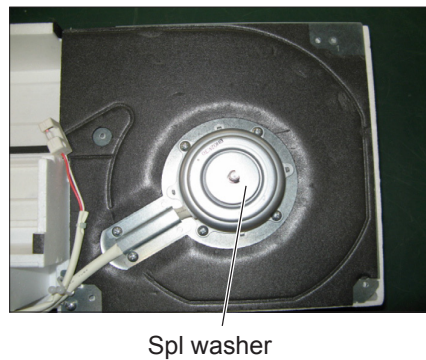

(8) Air supply (SA) fan

- ① Unscrew the motor fix plate clamping screw (one PTT screw 4 × 14, indicated by ○).

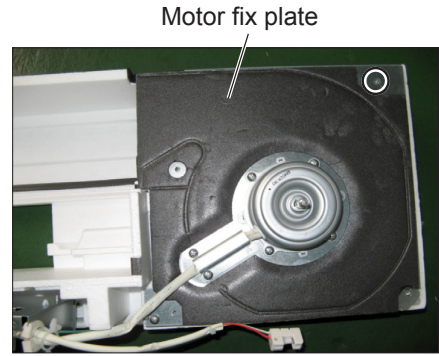

- ② Turn the motor fix plate upside down, and put it on the main unit.
- ③ Remove the special nut (8) and tab washer, and then remove the SA fan.

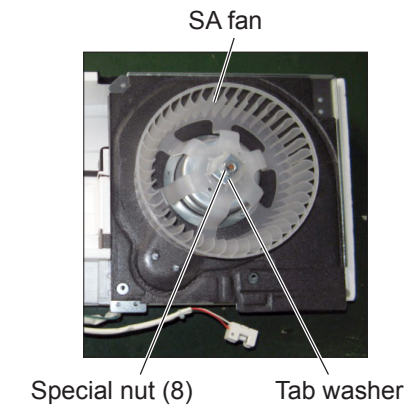

- ④ Remove the special (spl) washer (8) (16 mm in outer diameter).

Reassembly precaution
Be aware of the size difference between each washer for EA fan and SA fan.
Incorrect installation may cause unusual noise.

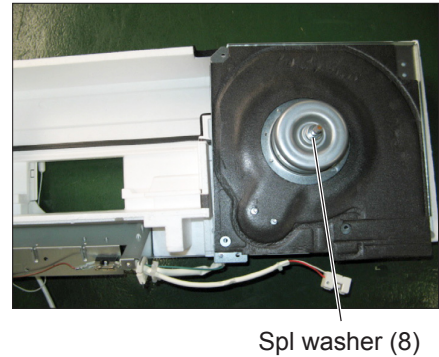

(9) Motor

- Unscrew the screws that clamps motor and lead cover (six PTT screws 4 × 10, indicated by ○), and then remove the motor.

Reassembly precaution
When installing the lead cover, make sure to place it under the motor (indicated by □).

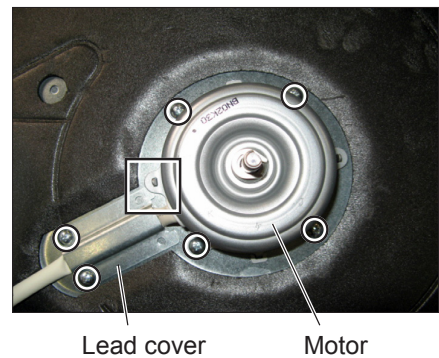

(10) Terminal block case (TB case)

- ① Unscrew the TB case clamping screw (one PT screw 4 × 8, indicated by ○), and remove the TB case.

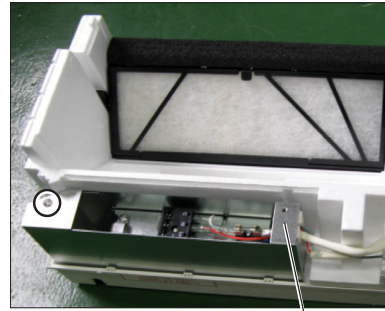

TB case

- ② Unscrew the TB fix plate clamping screws (two PTT screws 4 × 8, indicated by ○), and remove the TB fix plate.

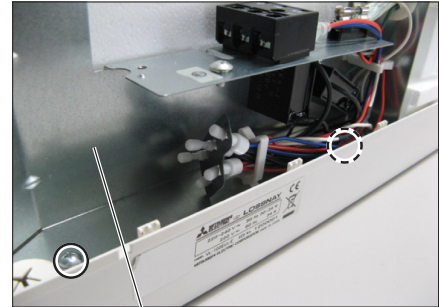

TB fix plate

(11) Fan casing

- Remove the fan casing (made of styrene foam).

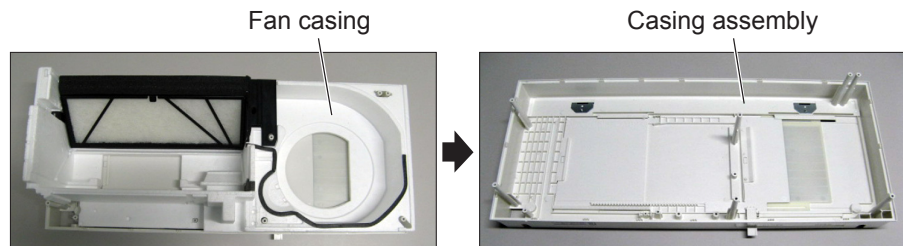

* When reassembling

- Reassemble the unit in the reverse order of disassembly.
- After reassembly, always make a test run to make sure that the unit operates properly.

10. Parts catalog

Please note the following when using the parts catalog.

1. When ordering parts, always indicate the part number, part name, and the number of parts required.
2. Parts are not always available, and it may take time for you to receive them.
3. There may be specification improvements.
4. Parts marked \triangle are critical for safety. To maintain safety and performance, always replace these parts with the parts prescribed.

Description of screw abbreviations

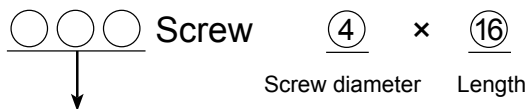

Abbreviation	Description
PC screw	Cross recess flat head machine screw
PRC screw	Cross recess oval head machine screw
PP screw	Cross recess pan head machine screw
SW · PP screw	Cross recess pan head screw with spring washer
PPT screw	Cross recess tapping screw
PCT screw	Cross recess flat head tapping screw
PTT screw	Cross recess truss head tapping screw
PT screw	Cross recess truss head machine screw
SET screw	Slotted head stop screw
SQ · SET screw	Square head stop screw
P · SET screw	Pan head stop screw
PMT screw	Primer truss head screw
HS · SET screw	Hexagon head stop screw
P · R · W screw	Cross recess round wood screw
P · C · W screw	Cross recess flat head wood screw
P · R · C · W screw	Cross recess round and flat wood screw
R · W screw	Slotted round wood screw
PW · PP screw	Cross recess pan head screw with small washer
SW-PW · PP screw	Cross recess pan head machine screw with spring washer and flat washer

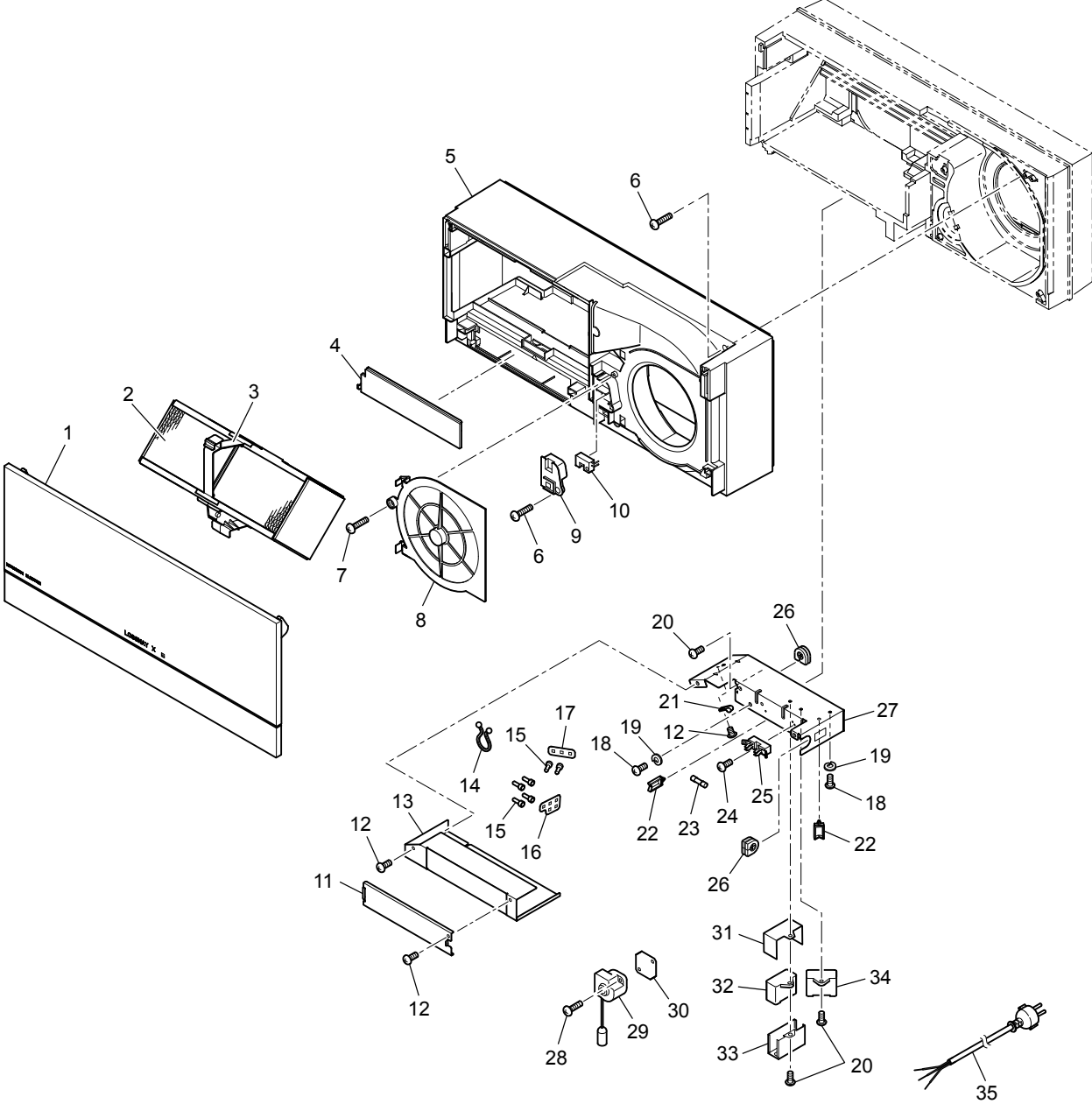

VL-100U5-E

No.	Name of part	Parts No.	Q'ty pcs/unit	Critical for safety	Remarks
1	Front panel	Y36 004 721	1		
2	Lossnay core	Y36 004 723	1	▲	
3	Core handle	Y36 004 722	1		
4	Cover	Y36 004 709	1		
5	Front casing	Y36 004 707	1		
6	PTT screw 4×14	H00 000 333	8		
7	PTT screw 4×10	M32 013 027	1		
8	Filter	Y36 004 717	1	▲	
9	Lamp cover	Y36 004 711	1		
10	Neon lamp	Y36 004 290	1	▲	
11	TB case cover	Y36 004 710	1		
12	PT screw 4×8	H00 000 349	3		
13	TB case	Y36 004 708	1		
14	Cord band	K83 170 228	1		White
15	Crimp cap	K82 181 240	6	▲	CE1(CE-100V)
16	Cord clamper	M35 855 223	1		
17	Cord clamper	M35 830 223	1		
18	PT screw 4×8 BS	H00 011 008	3		
19	Spg. washer (4)	H00 056 075	3		
20	PTT screw 4×8	H00 000 487	6		
21	Cord clip	X31 981 223	1		
22	Cord clip	D40 094 227	2		
23	Fuse	Y36 004 280	1	▲	1A·250V
24	PPT screw 3×10	H00 000 676	1		
25	Fuse holder	Y55 001 281	1		
26	Cord bush	M45 649 226	2		
27	TB fix plate	Y36 004 712	1		
28	PPT screw 4×10	H00 000 471	1		
29	Switch	Y36 004 255	1	▲	With a pull cord
30	Insulator sheet	M34 279 201	1	▲	
31	Capacitor case	M35 768 653	1		
32	Capacitor	M34 203 283	1	▲	4.0μF·220VAC
33	Capacitor cover	M35 275 652	1		
34	Capacitor	Y81 016 284	1	▲	1.5μF·440VAC
35	Power cord	Y36 004 220	1	▲	3200mm

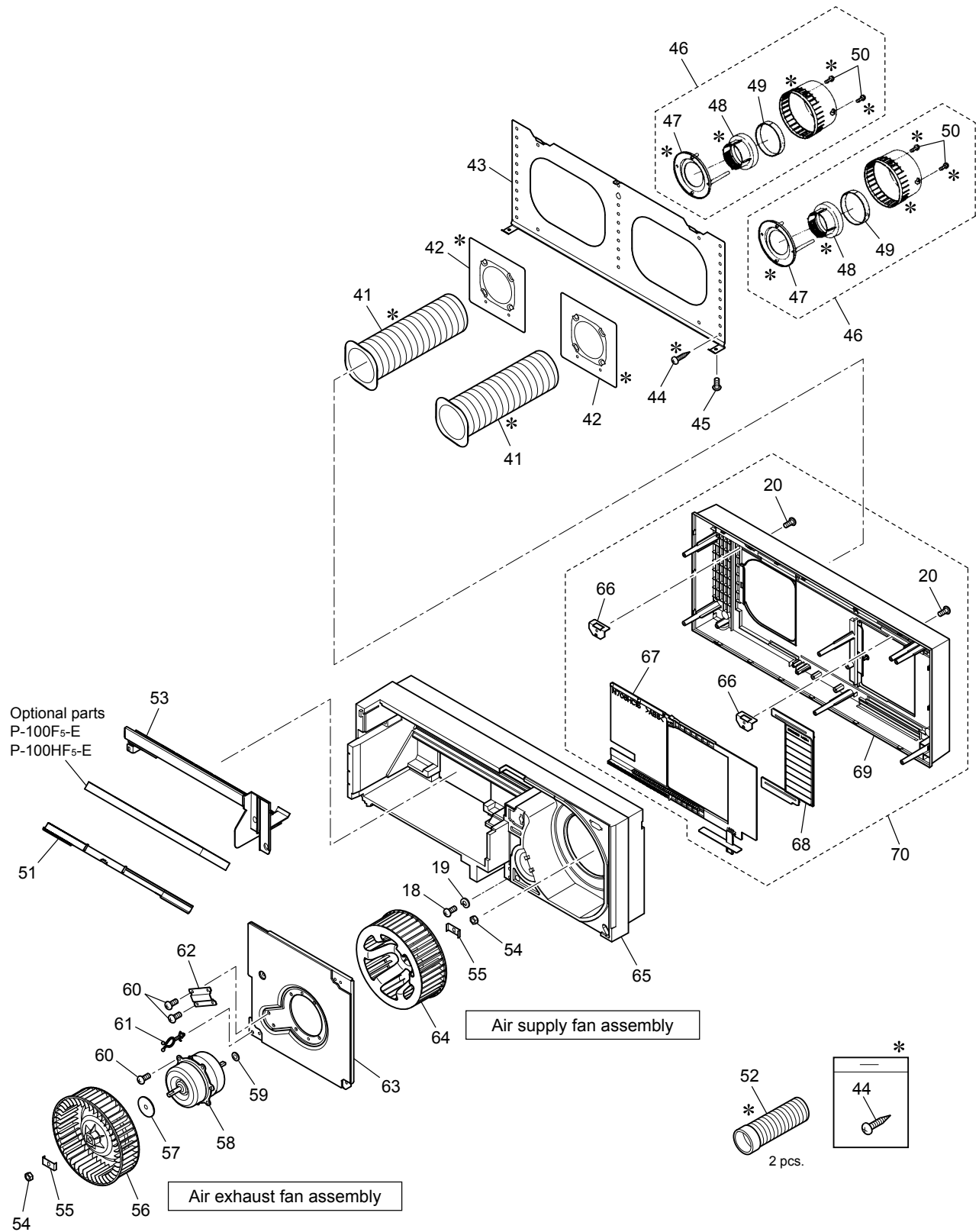

* shows accessory parts.

VL-100U5-E

No.	Name of part	Parts No.	Q'ty pcs/unit	Critical for safety	Remarks
41	Wall pipe	M36 091 731	2		
42	Pipe fix plate	M36 293 707	2		
43	Fix plate	M36 100 709	1		
44	Spl scr 3.5×32	M34 863 045	9		
45	PTT screw 4×8	M45 502 095	2		Black
46	Weather cover	M36 099 707	2		
47	Flange	M36 099 708	2		
48	Flange nut	M34 231 303	2		
49	Packing	M34 519 718	2		
50	PTT screw 4×12	D41 037 008	4		SUS
51	Filter stopper	Y36 004 714	1		
52	Pipe	Y36 004 706	2		
53	Filter frame	Y36 004 713	1		
54	Special nut (8)	X31 267 067	2		
55	Tab washer	M36 130 077	2		
56	Centrifugal fan	M36 265 480	1	▲	φ170
57	Spl washer	M36 265 080	1		φ40 (outer dia.)
58	Motor	Y36 004 453	1	▲	
59	Spl washer (8)	M34 365 080	1		φ16 (outer dia.)
60	PTT screw 4×10	H00 000 332	6		
61	Cord clamber	R50 062 223	1		
62	Lead cover	M36 169 712	1		
63	Motor fix plate	Y36 004 715	1		
64	Centrifugal fan	Y36 004 480	1	▲	φ170
65	Fan casing	Y36 004 724	1		
66	Mounting piece	M34 709 345	2		
67	Shutter	Y36 004 719	1		
68	Shutter	Y36 004 720	1		
69	Casing	Y36 004 716	1		
70	Casing assembly	Y36 004 725	1		With shutters

VL-100EU5-E

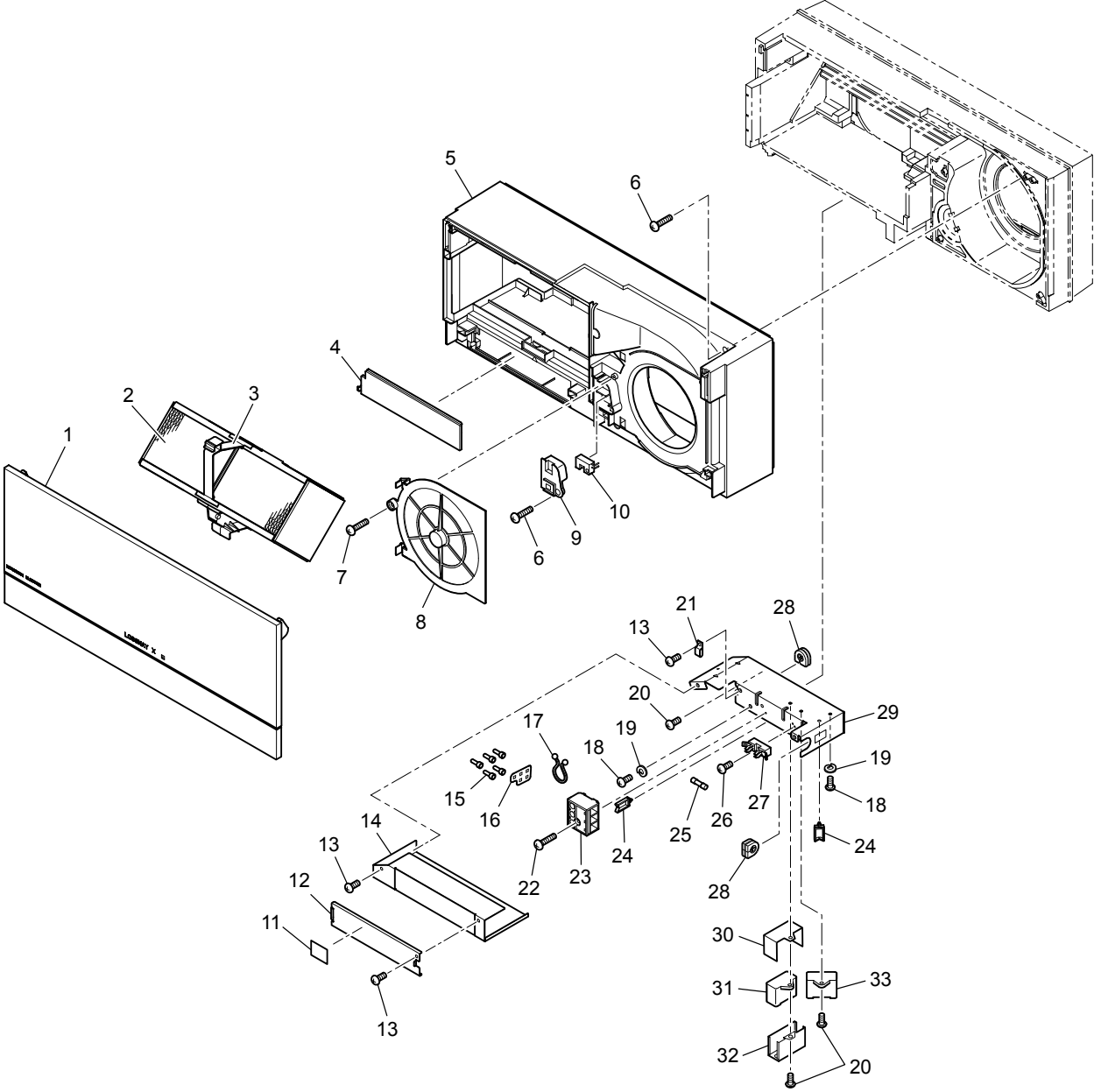

VL-100EU5-E

No.	Name of part	Parts No.	Q'ty pcs/unit	Critical for safety	Remarks
1	Front panel	Y36 004 721	1		
2	Lossnay core	Y36 004 723	1	▲	
3	Core handle	Y36 004 722	1		
4	Cover	Y36 004 709	1		
5	Front casing	Y36 004 707	1		
6	PTT screw 4×14	H00 000 333	8		
7	PTT screw 4×10	M32 013 027	1		
8	Filter	Y36 004 717	1	▲	
9	Lamp cover	Y36 004 711	1		
10	Neon lamp	Y36 004 290	1	▲	
11	Wiring diagram	Y36 005 357	1		
12	TB case cover	Y36 004 710	1		
13	PT screw 4×8	H00 000 349	3		
14	TB case	Y36 005 706	1		
15	Crimp cap	K82 181 240	5	▲	CE1(CE-100V)
16	Cord clamper	M35 855 223	1		
17	Cord band	K83 170 228	1		White
18	PT screw 4×8 BS	H00 011 008	3		
19	Spg. washer (4)	H00 056 075	3		
20	PTT screw 4×8	H00 000 487	6		
21	Cord clip	D40 134 227	1		
22	PPT screw 3×20	H00 005 005	1		
23	Terminal block	Y36 005 242	1	▲	3P
24	Cord clip	D40 094 227	2		
25	Fuse	Y36 004 280	1	▲	1A·250V
26	PPT screw 3×10	H00 000 676	1		
27	Fuse holder	Y55 001 281	1		
28	Cord bush	M45 649 226	2		
29	TB fix plate	Y36 005 707	1		
30	Capacitor case	M35 768 653	1		
31	Capacitor	M34 203 283	1	▲	4.0μF·220VAC
32	Capacitor cover	M35 275 652	1		
33	Capacitor	Y81 016 284	1	▲	1.5μF·440VAC

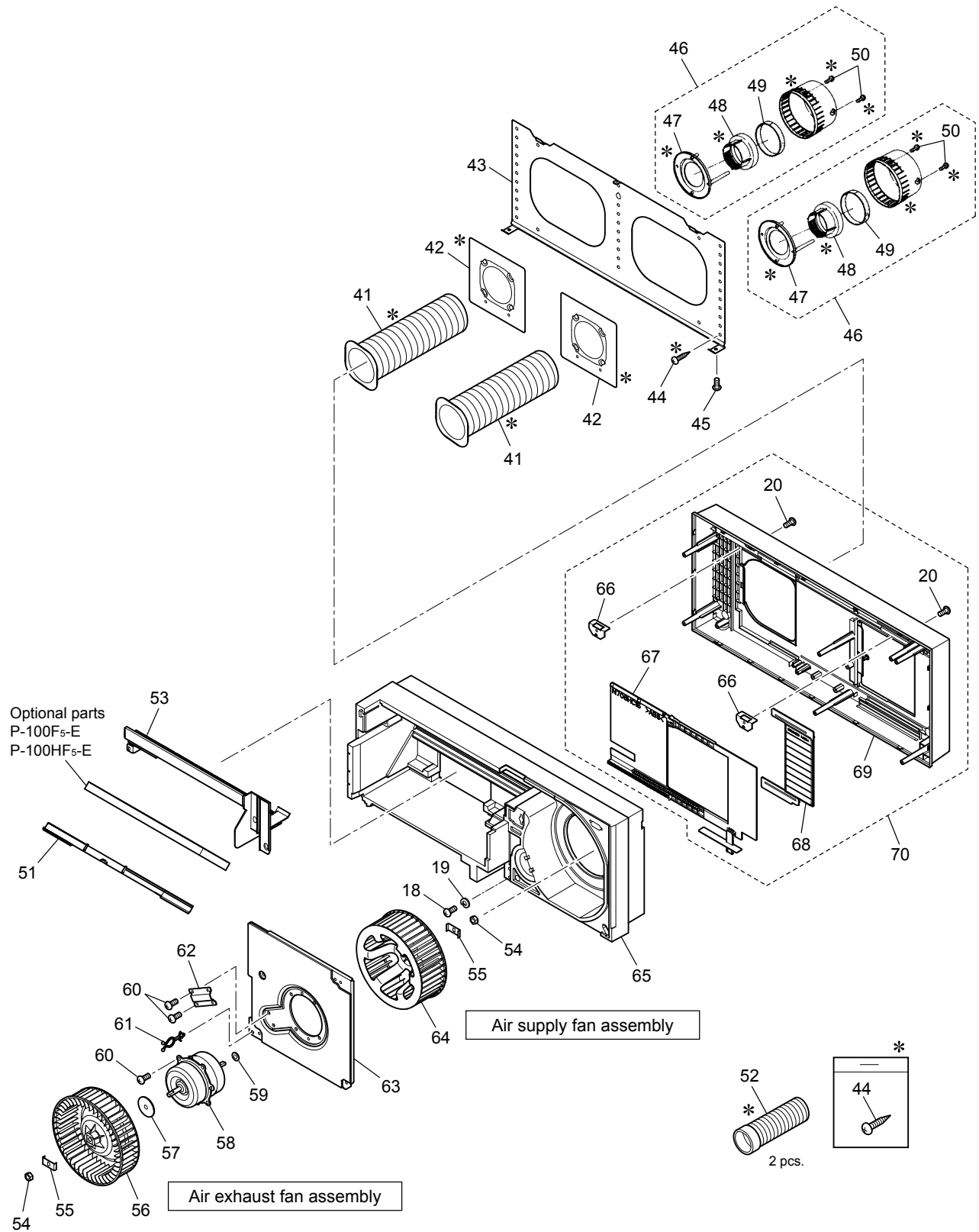

* shows accessory parts.

VL-100EU5-E

No.	Name of part	Parts No.	Q'ty pcs/unit	Critical for safety	Remarks
41	Wall pipe	M36 091 731	2		
42	Pipe fix plate	M36 293 707	2		
43	Fix plate	M36 100 709	1		
44	Spl scr 3.5×32	M34 863 045	9		
45	PTT screw 4×8	M45 502 095	2		Black
46	Weather cover	M36 099 707	2		
47	Flange	M36 099 708	2		
48	Flange nut	M34 231 303	2		
49	Packing	M34 519 718	2		
50	PTT screw 4×12	D41 037 008	4		SUS
51	Filter stopper	Y36 004 714	1		
52	Pipe	Y36 004 706	2		
53	Filter frame	Y36 004 713	1		
54	Special nut (8)	X31 267 067	2		
55	Tab washer	M36 130 077	2		
56	Centrifugal fan	M36 265 480	1	▲	φ170
57	Spl washer	M36 265 080	1		φ40 (outer dia.)
58	Motor	Y36 004 453	1	▲	
59	Spl washer (8)	M34 365 080	1		φ16 (outer dia.)
60	PTT screw 4×10	H00 000 332	6		
61	Cord clamber	R50 062 223	1		
62	Lead cover	M36 169 712	1		
63	Motor fix plate	Y36 004 715	1		
64	Centrifugal fan	Y36 004 480	1	▲	φ170
65	Fan casing	Y36 004 724	1		
66	Mounting piece	M34 709 345	2		
67	Shutter	Y36 004 719	1		
68	Shutter	Y36 004 720	1		
69	Casing	Y36 004 716	1		
70	Casing assembly	Y36 004 725	1		With shutters